

Service Manual

Digital Compact Cassette Deck

RS-DC10

DIGITAL
DCC
COMPACT CASSETTE

*
DOLBY B·C NR

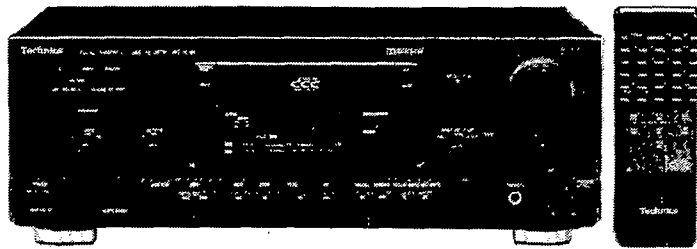

Colour

(K) ... Black Type

Area

Suffix for Model No.	Area	Colour
(EB)	Great Britain.	(K)
(EG)	Germany, Italy and Europe.	
(G)	Asia, Latin America, Middle Near East and Africa.	

*Dolby noise reduction manufactured under license from Dolby Laboratories Licensing Corporation. "Dolby" and the double-D symbol are trade marks of Dolby Laboratories Licensing Corporation.

NEW MECHANISM FOR RS-DC10 (AR350D)

SPECIFICATIONS

■ Digital Recording/Playback

Tape recording system: Stationary head type DCC
 Sampling frequencies
 (Analog input recording): 44.1 kHz
 (Playback/digital input recording):
 48 kHz, 44.1 kHz, 32 kHz
 (selected automatically)
 No. of quantizing bits: 16-bit linear
 Audio coding system: PASC
 No. of channels: 2-channel (stereo)
 Frequency response: 10 Hz–20,000 Hz (± 0.2 dB)
 (48 kHz sampling frequency):
 10 Hz–22,000 Hz (± 0.2 dB)
 (32 kHz sampling frequency):
 10 Hz–14,500 Hz (± 0.2 dB)
 THD
 (Playback): 0.003% or less (1 kHz, 0 dB)
 (Recording/playback): 0.005% or less (1 kHz, 0 dB)
 Dynamic range
 (Playback): 95 dB or more (A-weighted)
 (Recording/playback): 92 dB or more (A-weighted)
 S/N ratio
 (Playback): 98 dB or more (A-weighted)
 (Recording/playback): 92 dB or more (A-weighted)
 Channel separation
 (Playback): 95 dB or more (1 kHz)
 (Recording/playback): 80 dB or more (1 kHz)
 Wow and flutter: Below measurable limit

■ Analog Cassette Tape Playback

Deck system: Analog compact cassette
 Track system: 4-track, 2-channel (stereo)
 Frequency response (Dolby NR off)
 Normal: 30 Hz–15,000 Hz ± 3 dB
 CrO₂: 30 Hz–16,000 Hz ± 3 dB
 Metal: 30 Hz–17,000 Hz ± 3 dB
 S/N (signal level=250 nwb/m, CrO₂ type tape)
 NR off: 56 dB (A-weighted)
 Dolby B NR on: 65 dB (CCIR)
 Dolby C NR on: 74 dB (CCIR)
 Wow and flutter: 0.07% (WRMS)
 $\pm 0.2\%$ (DIN)

■ Terminals

Analog input
 Input sensitivity: 60 mV (-12 dB)
 Input impedance: 47 k Ω
 Analog output (Fixed)
 Output level: 500 mV (DCC: -12 dB)
 Maximum output level: 2 V (DCC: 0 dB)
 Output impedance: 440 Ω
 Variable analog
 Output: Using remote control
 Headphones output
 Maximum level: 30 mW+30 mW (32 Ω load)
 Load impedance range: 8–600 Ω
 Digital input: Coaxial 75 Ω /optical
 (with select SW)
 Digital output: Coaxial 75 Ω /optical
 (parallel output)

Technics

■ Mechanism

Heads: 20-channel thin film head
 Tape drive system: Single capstan drive (Auto reverse)
 Tape drive motors
 Capstan: DC servo motor
 Reel table: DC motor
 Tape speed: 4.76cm/sec. (1-7/8 ips.)
 Fast forward and rewind times:
 Approx. 100sec.
 with D-60 cassette tape

■ General

Power consumption: 35W
 Power supply:
 For (EG) area: AC 50/60 Hz, 230V
 For (EB) area: AC 50/60 Hz, 240V
 For (G) area: AC 50/60 Hz,
 110V, 120V, 240V, 220V
 Dimensions (W × H × D): 430 × 153 × 341 mm
 Weight: 8.3 kg

Note:
 Specifications are subject to change without notice.
 Weight and dimensions are approximate.

■ CONTENTS

	Page
ACCESSORIES	2
MAIN FEATURES OF DCC	3, 4
THIN-FILM HEAD AND TRACK DISTRIBUTION	4
CONNECTIONS	5
CAUTION FOR AC MAINS LEAD	6, 7
SEGGESTIONS FOR SAFETY	7
LOCATION OF CONTROLS	8, 9
ABOUT DCC TAPE	10
SCMS	11, 12
HANDLING PRECAUTIONS FOR DCC HEAD	13
HEAD CLEANING METHOD	13
DISASSEMBLY INSTRUCTIONS	14~18
HEAD ASS'Y REPLACEMENT	18
OPERATIONAL CHECKING PROCEDURE	19, 20
MECHANISM BLOCK CHECK	21, 22
HOW TO USE "SERVICE MODE"	23
ABOUT THE OPERATIONAL CHECKING POINTS	24~28
BLOCK DIAGRAM	29~33

	Page
SCHEMATIC DIAGRAM	34~53
TERMINAL GUIDE OF IC'S, TRANSISTORS AND DIODES	54
INTERNAL CONNECTION OF FL	55
WIRING CONNECTION DIAGRAM	56, 57
PRINTED CIRCUIT BOARDS	58~65
PACKAGING	66
REPLACEMENT PARTS LIST	67~70
RESISTORS AND CAPACITORS	71~74
EXPLODED VIEWS (Cabinet parts loading parts and Mechanical parts)	75~79
REPLACEMENT PARTS LIST	80, 81
MEASUREMENT AND ADJUSTMENT	

Note: • Refer to the measurement and adjustment of supplement manual (Order No. AD9212389C8).

■ ACCESSORIES

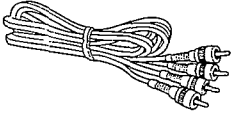
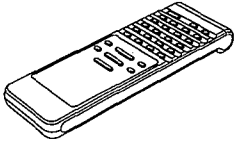
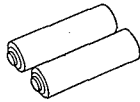
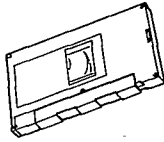
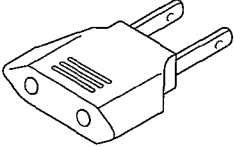
 • Stereo connection cable (SFDHM03N02)..... 2 pcs.	 • Remote control transmitter (ZK011D0020)..... 1 pc.	 • Batteries..... 2 pcs. for remote control transmitter *〈UM-4, "AAA" (R03)〉
 • DCC tape..... 1 pc. for recording purposes *(RT-D60E)	 • Power plug adaptor (YJ04001280) for (G) area only	

* These are available on sale route.

■ MAIN FEATURES OF DCC

1. Compatibility with Conventional Analog Format

■ Backward Compatibility

Since every DCC machine can also play analog compact cassettes, DCC is sure to be acceptable to most users. This backward compatibility is particularly attractive in car audio and headphone stereo applications. It saves space since only one machine is needed to play cassettes in either format. There's no need to carry or install separate players for analog and digital.

To provide this compatibility, all DCC machines have bi-directional auto reverse operation, using a unique half digital, half analog head configuration.

■ Mechanical Simplicity

DCC machines use a stationary head configuration, rather than the helical scan rotating head system required for DAT (and VCRs). Except for the head itself, analog tape transports can, for the most part, be used for DCC.

■ Plentiful Musicassettes

DCC has enlisted the support of the world's major record companies. Working with the Philips team, some of them even participated in DCC development.

Whereas there were only a small number of disc titles when the CD first came out, an extremely wide variety and large number of prerecorded titles will be available on DCC from the very first day the format is launched.

In addition, existing 32-times and 64-times high speed tape duplication equipment requires only slight modification to handle dubbing of DCC tapes, so manufacturing costs of prerecorded DCC cassettes promise not to be significantly higher than those of analog prerecorded cassettes.

2. Latest in Digital Technology

■ PASC — Newly Developed Intelligent Coding System

Without PASC, the DCC format could not use a linear-tracking stationary head and ordinary coercivity tape, and therefore would not achieve playback compatibility with analog cassettes. PASC effectively reduces the amount of information that needs to be stored, thereby lessening the storage density requirements of the media and the bit-rate requirements during write/read (recording/playback) operations. You could say that PASC lightens the work load of the transducers (heads) and media (tape) by taking an "intelligent" approach to the coding process.

To understand this difference, let's take a look at linear PCM coding first. Despite the incredible precision and sophistication of linear PCM, it is not designed, nor in fact is it necessary, to consider which data is essential and which is irrelevant. Linear PCM is designed to simply encode all the data presented to it. The result of linear PCM is an output waveform that is physically identical to the input waveform (after anti-aliasing low-pass filtering). All of the measurable information contained in the original input waveform is retained in the reproduced output waveform.

PASC, in contrast, analyzes the input waveform to determine which portions are really needed. Such an approach may appear heretical to audio purists, but it is in fact the basis of many already widely accepted technologies.

PASC — High Efficiency Intelligent Coding

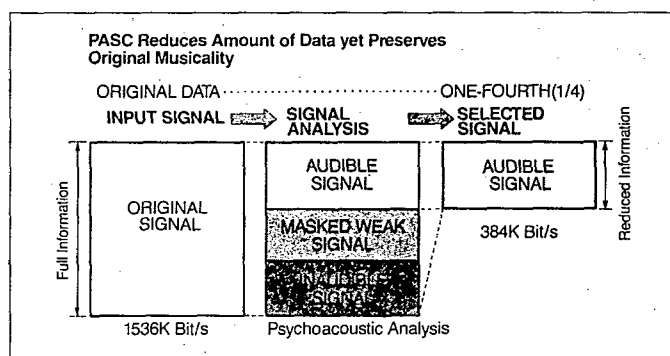

Fig. 1

As shown here PASC simply applies proven psychoacoustic principles, such as the masking effect and hearing threshold, to economize on data. Therefore, instead of reproducing what the original waveform looks like, PASC reproduces what the original waveform sounds like.

Since this is, to a large extent, a value judgment, audio engineers from a major record company were involved in the fine-tuning of PASC to assure the system offered outstanding "musicality."

DCC Player/Recorder Block Diagram

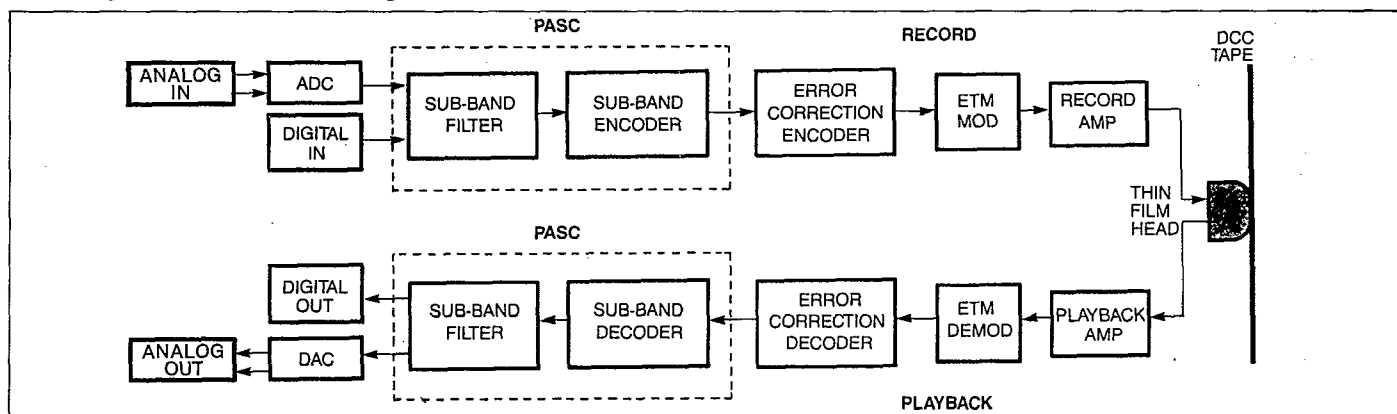

Fig. 2

PASC Encoding Process

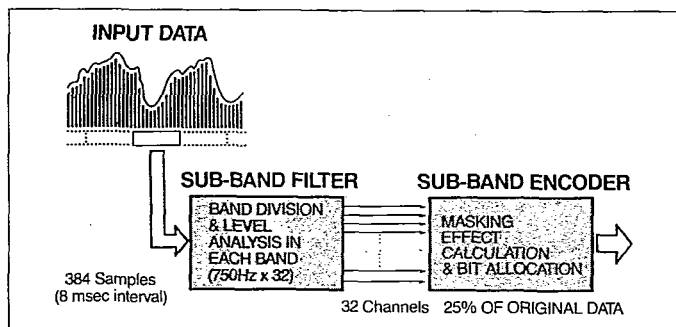

Fig. 3

PASC Decoding Process

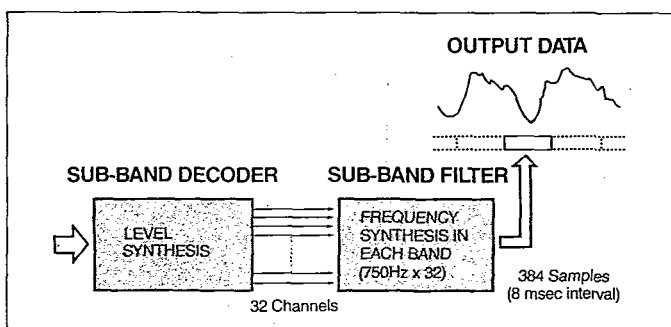

Fig. 4

THIN-FILM HEAD AND TRACK DISTRIBUTION

1. Eight Digital Tracks plus One Auxiliary Track

DCC tape is divided into an upper sector (forward) and lower sector (reverse), physically corresponding to side B (reverse) and side A (forward) of an analog tape. Each sector comprises eight tracks for digital audio data and one track for auxiliary data.

Recording lays down tracks 185 microns wide, whereas playback looks at only a 70 micron portion of this width. This means that transport accuracy becomes less critical, the possibility of mistracking is virtually eliminated, and manufacturers can largely use existing analog cassette transport components.

Digital Track Distribution

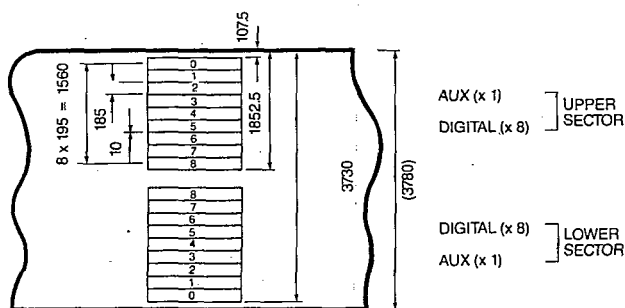

Fig. 5

2. Stationary Thin-Film Head

Along with PASC, this was another key to the development of DCC equipment. To handle its narrow track pitch of 195 microns, DCC uses a precision head fabricated by thin-film technology (related to the lithographic process employed in LSI manufacturing).

For recording, new digital data is simply overwritten so no separate erase facility is provided. For bi-directional operation, head configurations will be: a) turnover type digital 9-track head (upper) and analog 2-track head (lower), or b) fixed-type twin head.

DCC Thin-Film Head Structure

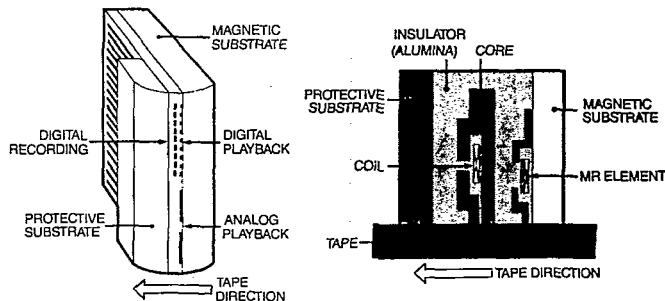

Fig. 6

CONNECTIONS

Be sure to turn off the power to all the components before proceeding to connect them. Connect the power cable only after all the other connections have been performed.

An example of the connections is given below. For further details, consult the Operating Instructions of the components involved as well.

Digital connections

There are two ways to perform the digital connections: either connect a digital amplifier to the deck or connect another digital component directly to the deck.

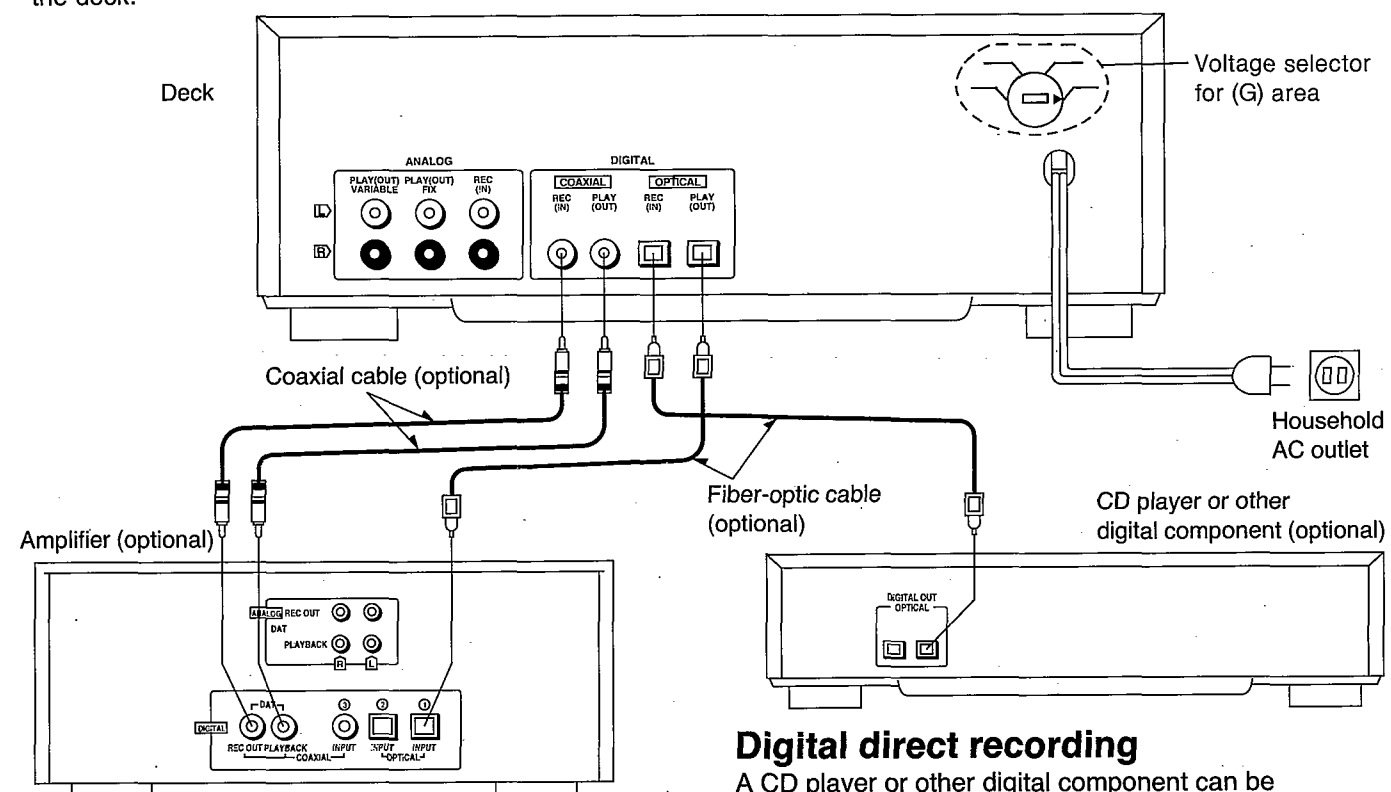

Digital direct recording

A CD player or other digital component can be connected directly to the deck and the digital signals of that component can be recorded without further ado. (See "SCMS" on pages 11 and 12.)

About Optical Fiber Cables

To connect optical fiber cables

- ① Remove the dust cap from the terminal.
- ② Connect the cable to the terminal.

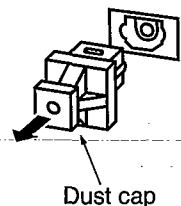

Dust cap

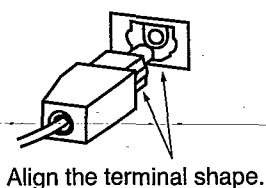

Align the terminal shape.

Do not attempt to bend optical fiber cables at severe angles. Be sure that connections are made securely.

Store the dust cap securely, and replace it whenever cables are not connected to the terminals. If dust is allowed to enter the terminal connector, signal errors may result.



About OPTICAL connector

When the optical connectors are used, electrical signals are converted into light signals for transmission between units, making the signals impervious to adverse effects from external noise. This form of connection thus allows the highest quality of digital audio signal transmission.

CAUTION FOR AC MAINS LEAD

FOR (EB) area only

For your safety, please read the following text carefully.

This appliance is supplied with a moulded three pin mains plug for your safety and convenience. A 5-ampere fuse is fitted in this plug. Should the fuse need to be replaced please ensure that the replacement fuse has a rating of 5-ampere and that it is approved by ASTA or BSI to BS1362. Check for the ASTA mark  or the BSI mark  on the body of the fuse.

If the plug contains a removable fuse cover you must ensure that it is refitted when the fuse is replaced. If you lose the fuse cover the plug must not be used until a replacement cover is obtained. A replacement fuse cover can be purchased from your local dealer.

CAUTION!

IF THE FITTED MOULDED PLUG IS UNSUITABLE FOR THE SOCKET OUTLET IN YOUR HOME THEN THE FUSE SHOULD BE REMOVED AND THE PLUG CUT OFF AND DISPOSED OF SAFELY. THERE IS A DANGER OF SEVERE ELECTRICAL SHOCK IF THE CUT OFF PLUG IS INSERTED INTO ANY 13-AMPERE SOCKET.

If a new plug is to be fitted please observe the wiring code as shown below. If in any doubt please consult a qualified electrician.

IMPORTANT

The wires in this mains lead are coloured in accordance with the following code:

- Blue: Neutral
- Brown: Live

As the colours of the wires in the mains lead of this appliance may not correspond with the coloured markings identifying the terminals in your plug, proceed as follows:

The wire which is coloured BLUE must be connected to the terminal in the plug which is marked with the letter N or coloured BLACK.

The wire which is coloured BROWN must be connected to the terminal in the plug which is marked with the letter L or coloured RED.

Under no circumstances should either of these wires be connected to the earth terminal of the three pin plug marked with the letter E or the Earth Symbol .

Before use

Remove the connector cover as follows.

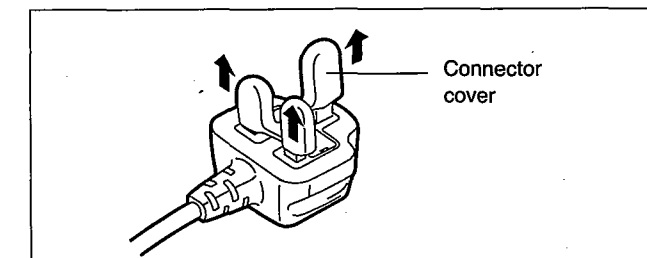

Connector cover

How to replace the fuse

1. Remove the fuse cover with a screwdriver.

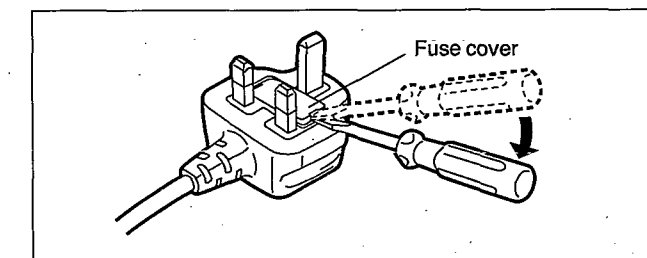

Fuse cover

2. Replace the fuse and attach the fuse cover.

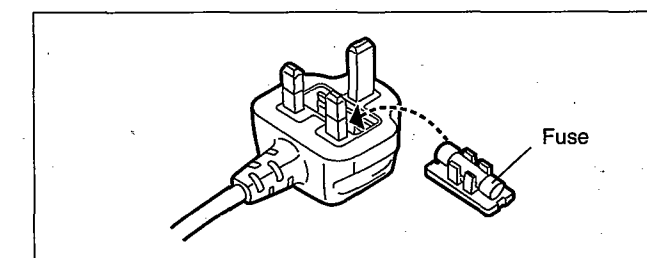

Fuse

FOR (G) area only

Be sure to disconnect the mains cord before adjusting the voltage selector.

Use a minus (-) screwdriver to set the voltage selector (on the rear panel) to the voltage setting for the area in which the unit will be used.

(If the power supply in your area is 117 V or 120 V, set to the "127 V" position.)

Note that this unit will be seriously damaged if this setting is not made correctly. (There is no voltage selector for some countries; the correct voltage is already set.)

■ SUGGESTIONS FOR SAFETY**■ Use a standard AC wall outlet**

1. **Use from an AC power source of high voltage, such as that used for an air conditioner, is very dangerous.**

A fire might be caused by such a connection.

2. **A DC power source cannot be used.**

Be sure to check the power source carefully, especially on a ship or other place where DC is used.

■ Grasp the plug when disconnecting the power supply cord

1. **Wet hands are dangerous.**

A dangerous electric shock may result if the plug is touched by wet hands.

2. **Never place heavy items on top of the power supply cord, nor force it to bend sharply.**

■ Place the unit where it will be well ventilated

Place this unit at least 10 cm (4") away from wall surfaces, etc.

Be careful that curtains and similar materials do not obstruct the ventilation holes.

■ Avoid places such as the following: In direct sunlight or in other places where the temperature is high.

In places where there is excessive vibration or humidity.

Such conditions might damage the cabinet and/or other component parts and thereby shorten the unit's service life.

■ Be sure to place the unit on a flat, level surface.

If the surface is inclined, a malfunction may result.

If the power plug will not fit your Household AC outlet, use the power plug adaptor (included).

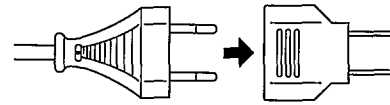
**■ Never attempt to repair nor reconstruct this unit**

A serious electric shock might occur if this unit is repaired, disassembled or reconstructed by unauthorized persons, or if the internal parts are accidentally touched.

■ Take particular care if children are present

Never permit children to put anything, especially metal, inside this unit. A serious electric shock or malfunction could occur if articles such as coins, needles, screwdrivers, etc. are inserted through the ventilation holes, etc. of this unit.

■ If water is spilled on the unit

Be extremely careful if water is spilled on the unit, because a fire or serious electric shock might occur. Immediately disconnect the power cord plug, and consult with your dealer.

■ Avoid spray-type insecticides

Insecticides might cause cracks or "cloudiness" in the cabinet and plastic parts of this unit. The gas used in such sprays might, moreover, be ignited suddenly.

■ Never use alcohol or paint thinner

These and similar chemicals should never be used, because they might cause flaking or cloudiness of the cabinet finish.

■ Disconnect the power supply cord if the unit will not be used for a long time

If the unit is left for a long time with the power ON, this not only will shorten its useful operation life, but also may cause other trouble.

■ If trouble occurs

If, during operation, the sound is interrupted or indicators no longer illuminate, or if an abnormal odour or smoke is detected, immediately disconnect the power cord plug, and contact with your dealer or an Authorized Service Center.

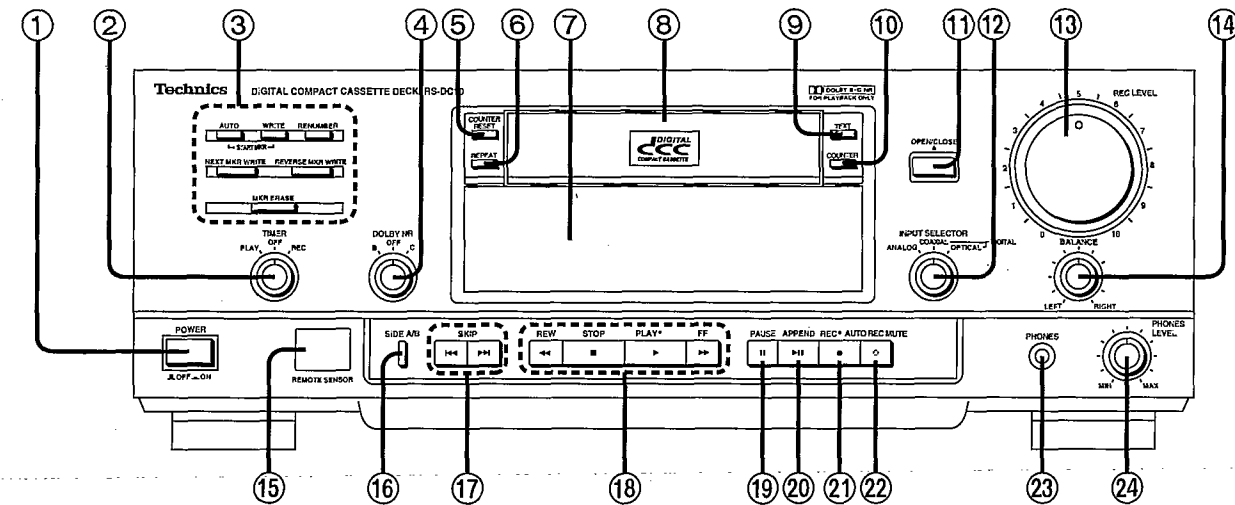
■ LOCATION OF CONTROLS**Control section**

- ① **Power switch (POWER)**

- ② **Timer switch (TIMER)**

Use this when a timer from an audio store has been connected to start playback or recording at a particular time.

- ③ **Marker control section**

AUTO START MKR:

For setting the start marker's writing mode to automatic or manual.

START MKR WRITE:

For writing the start marker manually.

RENUMBER:

For renumbering the track sequence when correcting the track numbers.

NEXT MKR WRITE:

For writing the next marker which automatically activates playback from the start of the reverse side.

REVERSE MKR WRITE:

For writing the reverse marker which automatically reverses the tape side from A to B.

MKR ERASE:

For erasing written markers.

- ④ **Dolby NR selector (DOLBY NR)**

This can be set to Dolby B, C or OFF, depending on which Dolby position, if any, was used for the recording on the analog cassette tape which is to be played back.

- ⑤ **Counter reset button (COUNTER RESET)**

Use this to return the tape counter to "0000".

- ⑥ **Repeat mode selector button (REPEAT)**

Use this to switch to the repeat play mode.

- ⑦ **Display section**

(See page 7 for details.)

- ⑧ **Cassette tray**

- ⑨ **Text information selector button (TEXT)**

Use this to select what is to be displayed—the title of the track now being played, etc.

- ⑩ **Counter selector button (COUNTER)**

Use this to select the tape counter's display mode.

- ⑪ **Cassette tray open/close button (OPEN/CLOSE)**

Use this to open or close the cassette tray.

- ⑫ **Input selector (INPUT SELECTOR)**

Use this to select the analog (ANALOG)/digital input (COAXIAL/OPTICAL).

- ⑬ **Recording level control (REC LEVEL)**

Use this to adjust the recording level when analog input signals are being recorded.

- ⑭ **Balance control (BALANCE)**

Use this to adjust the balance between the left and right channels when analog input signals are being recorded.

- ⑮ **Remote control sensor (REMOTE SENSOR)**

- ⑯ **Tape travel selector button (SIDE A/B)**

Use this to select the direction in which the tape is to travel.

- ⑰ **Skip buttons (SKIP |◀◀/▶▶|)**

Use these to skip to the track you want to hear.

- ⑱ **Basic control section**

Rewind button (REW ◀◀)
Stop button (STOP ■)
Play button and indicator (PLAY ▶)
Fast forward button (FF ▶▶)

- ⑲ **Pause button (PAUSE ||)**

- ⑳ **Append recording button (APPEND ▶||)**

Use this to search for the end of the recorded section on the tape where more material is to be appended, and set the deck to the recording standby mode.

- ㉑ **Record button and indicator (REC ●)**

- ㉒ **Recording mute button (AUTO REC MUTE ○)**

Use this to create unrecorded blanks between tracks on the tape.

- ㉓ **Headphones jack (PHONES)**

- ㉔ **Headphone volume control (PHONES LEVEL)**

Display section

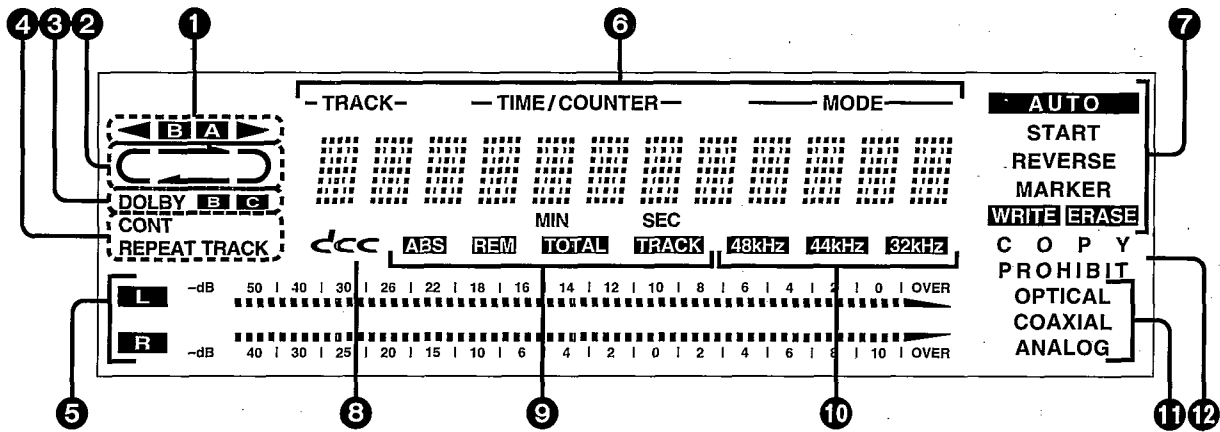

1 Tape travel direction indicators

(◀ B / A ▶)

These indicators show the direction in which the tape is traveling.
(The B / A display appears only when a DCC tape is used.)

2 Reverse mode indicator

This indicates the reverse mode.
(For analog cassette tapes only)

3 Dolby NR indicators (DOLBY B C)

These indicate the type of Dolby noise reduction which has been selected. When both of these indicators are off, it means that neither type of Dolby noise reduction has been selected.

4 Repeat mode indicators (CONT REPEAT/REPEAT TRACK)

CONT REPEAT:

All tracks are repeated.

REPEAT TRACK:

The track being played is repeated.
(For DCC tapes only)

5 Level meters

These indicate the input levels during recording and the levels recorded on the tape during playback.
When a DCC tape is used, the values at the top are displayed; when an analog cassette is used, the values at the bottom are displayed.

6 Text information/counter display section

When a prerecorded DCC music tape is played back, text information relating to what is being played appears on the display.

Track number display (TRACK):

This indicates the number of the track which is being played back or recorded.

Timer/counter display (TIME/COUNTER):

This indicates how many minutes and seconds of the track which is being played back or recorded have elapsed or it shows the tape counter display.

Mode display (MODE):

This indicates the operating mode which is currently established.

7 Marker indicator section

Start marker automatic indicator (AUTO):

This lights when the start marker is set to the automatic writing mode.

Start marker indicator (START):

This lights when the start marker has been written manually or when the start marker position is reached.

Reverse marker indicator (REVERSE):

This lights when the reverse marker has been written or when the reverse marker position is reached.

Marker indicator (MARKER):

This lights when any of the marker positions is reached.

Marker write indicator (WRITE):

This lights while a marker is being written.

Marker erase indicator (ERASE):

This lights while a marker is being erased.

8 DCC indicator (DCC)

This lights only when a DCC tape is being used.

9 Counter display indicators

(ABS, REM, TOTAL, TRACK)

The indicator corresponding to the setting of the COUNTER selector button is selected as follows.

ABS : Absolute time display

REM : Time remaining on one side of the tape

REM TOTAL : Total time remaining on the tape

TRACK : Elapsed time of track now being played.

10 Sampling frequency indicators

(48kHz, 44kHz, 32kHz)

These indicate the sampling frequency during the playback or recording of digital signals.
(For DCC tapes only)

11 Input indicator section

The indicators listed below light up when the INPUT selector has been set to the corresponding positions.

Optical input indicator (OPTICAL)

Coaxial input indicator (COAXIAL)

Analog input indicator (ANALOG)

12 Digital copy prohibit indicator (COPY PROHIBIT)

This lights when a copy prohibit signal is included among the source signals when digital input signals are supplied.

■ ABOUT DCC TAPE

Types of tapes which can be used

The types of tapes described below can be used with this deck.

Digital compact cassette tapes (DCC)

There are two types of DCC tapes.

1. Prerecorded DCC music tapes available in stores:
For playback only
2. DCC tapes for recording

Conventional analog cassette tapes: For playback only (Analog compact cassette tapes)

DCC tapes for recording

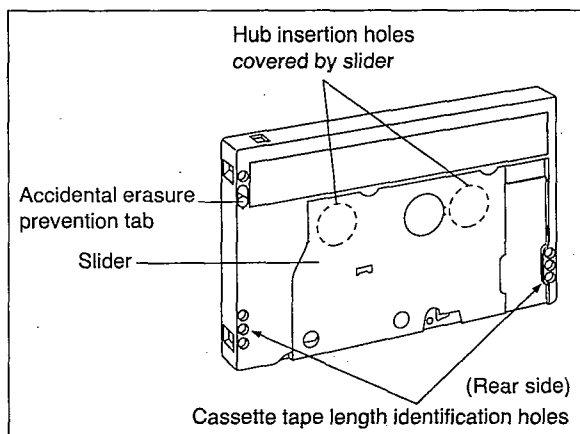

Unlike analog cassette tapes, DCC tapes are completely sealed, and their tape and hub holes are protected by a slider.

This design ensures that, except when the cassette is loaded, dust and foreign particles will not enter the cassette housing and cause dropouts (digital signal losses) which are the main cause of deterioration in the quality of digital recordings.

DCC tapes for recording come in lengths of 45, 60 and 90 minutes.

Tampering with the cassette tape length identification holes in any way can cause malfunctioning.

Safeguarding against the accidental erasure of a valuable recording

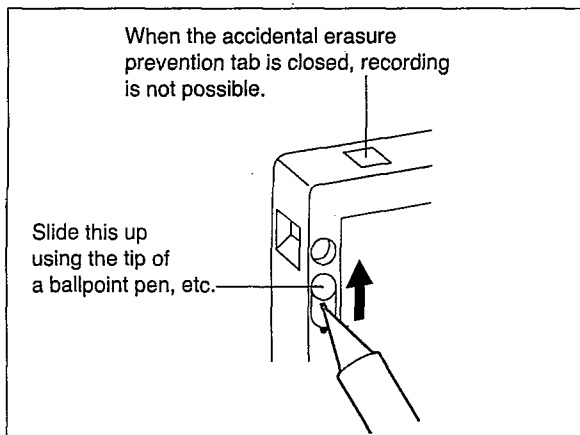

Recorded tapes that you want to keep can be protected by sliding the accidental erasure prevention tab on the rear side of the cassette to the "up" position shown in the diagram. It will then be impossible to record on the tape, thus protecting important recordings from accidental erasure.

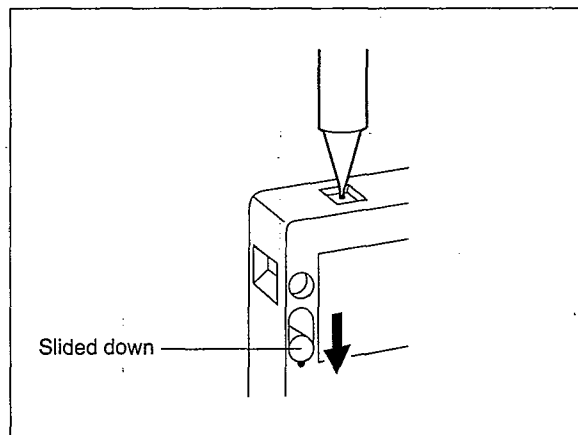

To re-record

Return the accidental erasure prevention tab to its indented (open) position.

Handling precautions

Do not open the cassette's slider to pull the tape out or touch it.

Take care not to drop the cassette, hit it or subject it to strong vibration.

The cassette cannot be turned over and used.

Storage precautions

Replace the cassette in its case and store away.

Do not place or store tapes in the following places:

1. Where it is very hot (over 35°C) or very humid (over 80%)
2. Where there are strong magnetic fields (near speakers or on top of a TV set, etc.)
3. Where the tapes will be exposed to direct sunlight

■ SCMS (SERIAL-COPY-MANAGEMENT-SYSTEM)

This unit is equipped with SCMS (Serial Copy Management System). SCMS is a system which allows digital-signal copying of CDs and commercial music DCC tapes only for one "generation". The DCC tape thus recorded cannot be used as a master tape

to produce further generations (serial copies) of the first digital copy. The accompanying illustrations describe the ways in which recording is possible from each kind of source.

1 DCC tapes recorded digitally from CDs

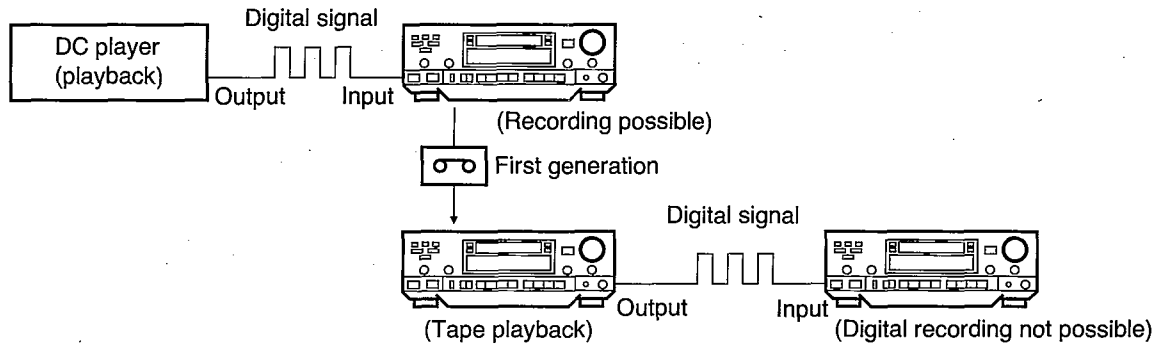

Digital-signal recording from a CD can be performed only for the first generation of DCC tape. The DCC tape thus recorded (1st generation) cannot be used as a master to make further digital copies (serial copies).

Digital signals from a CD player recorded on a DAT cannot be recorded in their original form from the DAT tape onto a digital compact cassette tape in their original form. Similarly, digital signals from a CD player recorded onto a DCC in their original form cannot be recorded from the DCC tape onto a digital audio tape in their original form. In other words, SCMS restricts the recording of digital signals even when different digital recording equipment such as DAT and DCC are used in combination.

2 DCC tapes recorded digitally from a commercially produced music DCC tape or DAT cassette

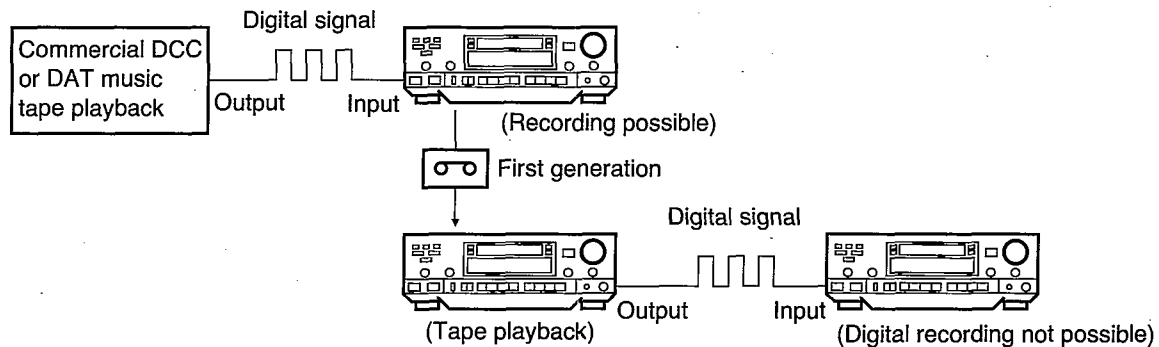

Digital-signal recording from a commercially produced DCC or DAT music tape can be performed only for the first generation of DCC tape. The DCC tape thus recorded (1st generation) cannot be used as a master to make further digital copies (serial copies).

However, it should be noted that it may not be possible to make digital copies from commercial DCC or DAT music tapes which do not conform to the SCMS format.

3 DCC tape recorded from analog input terminals (when thereafter recorded digitally)

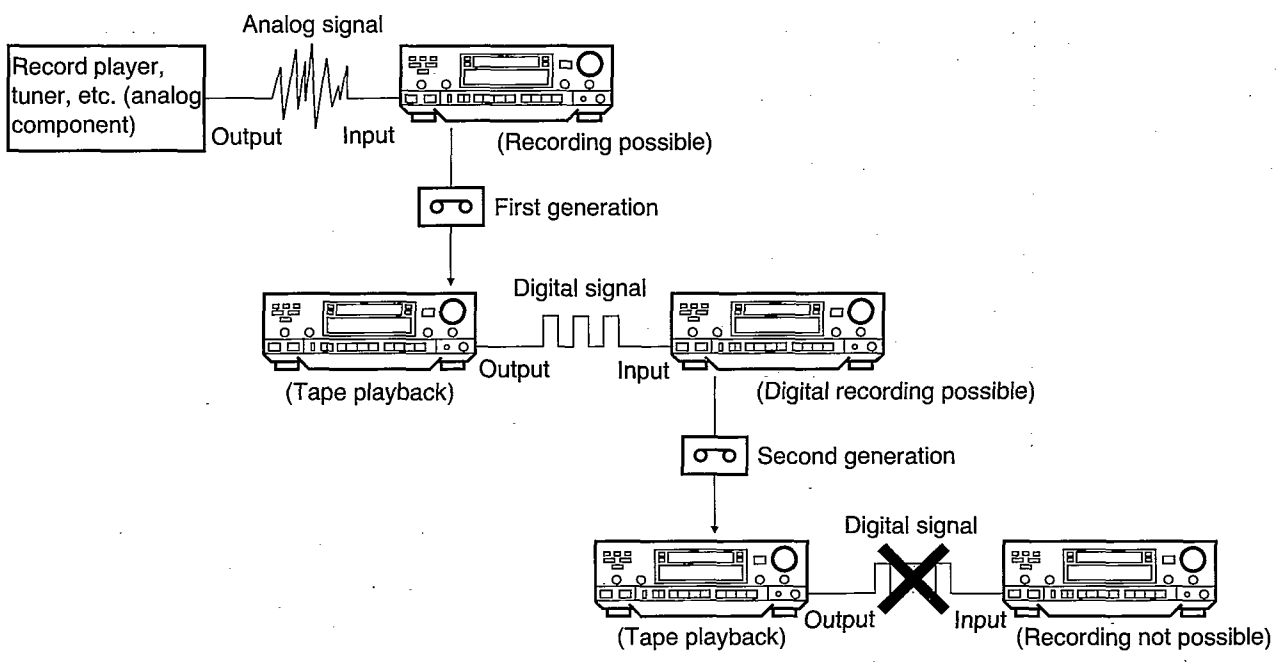

When the DCC recording of an analog source is used as the master tape for further digital-signal DCC copies, up to two generations of digital copies can be made. However, the second generation of such

copies cannot be used as the master tape for making third and subsequent generations of digital copies (serial copies).

4 DCC tapes recorded from analog input terminals (when recorded in analog thereafter)

When recording is performed from the analog input terminals, no restrictions are made on copies, in the same way as for conventional audio cassette tape recorders. Accordingly, even in cases where

recording of the digital signal (digital copy) is not possible, the analog input and output terminals can be used to perform analog recording.

Digital copy prohibit display

In the following cases, digital signals cannot be recorded in their original form:
 When recording signals from a source which has been digitally copied once before

The COPY PROHIBIT indicator lights.



When a copy prohibit signal is supplied during recording

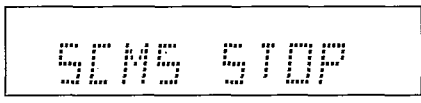

When a copy prohibit signal is supplied in the recording standby mode

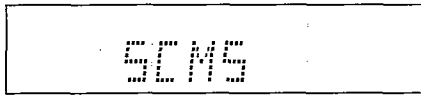

HANDLING PRECAUTIONS FOR DCC HEAD

Because static electricity or magnetism can damage the DCC head, please observe the following when handling the DCC head.

1) Caution on magnetism

Be sure to use only the designated screwdriver (RFKZ0037) when making aztec adjustment.

Never use a steel screwdriver or other screwdriver whose blade or tip is magnetized. Keep the DCC head away from all magnetized objects.

2) Caution on static electricity

Be sure to insert a shorting clip in the terminal of the FPC board (DCC head).

Connect the FPC board to the PCB connector as quickly as possible.

3) Others

Be especially careful not to use force when manipulating the FPC board or it will break or disconnect.

• Grounding for electrostatic breakdown prevention

1. Human body grounding

Use the anti-static wrist strap to discharge the static electricity from your body.

2. Work table grounding

Put a conductive material (sheet) or steel sheet on the area where the DCC head is placed, and ground the sheet.

Note:

It is important to ground the instrument before testing. Use either the ground contact of a nearby 3P wall outlet, or connect it to the frame ground of an instrument which is connected a 3P wall outlet.

Caution:

The static electricity of your clothes will not be grounded through the wrist strap. So, take care not to let your clothes touch the DCC head.

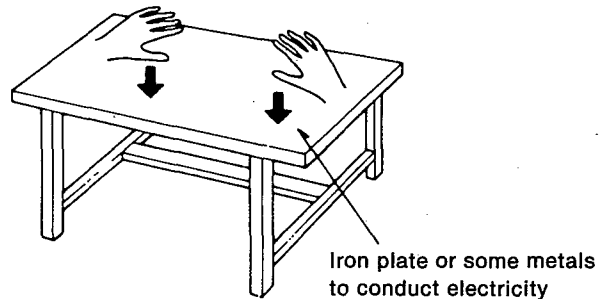
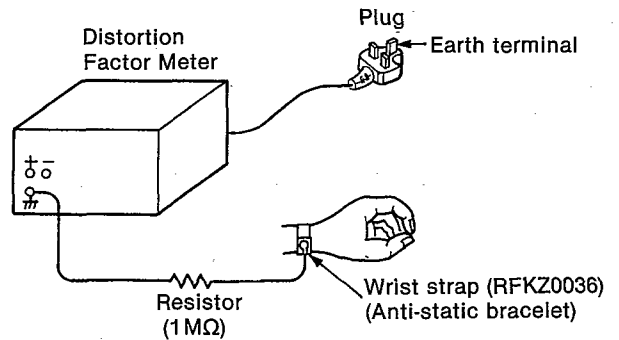
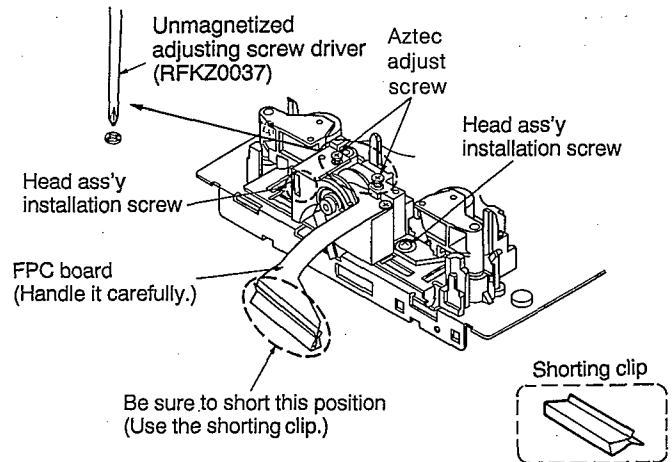

HEAD CLEANING METHOD

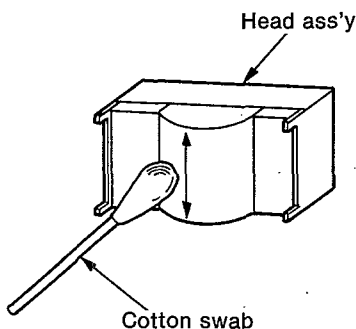

Clean the head up and down with a cotton swab slightly moistened with alcohol.

DISASSEMBLY INSTRUCTIONS

"ATTENTION SERVICER"

Some chassis components may have sharp edges. Be careful when disassembling and servicing.

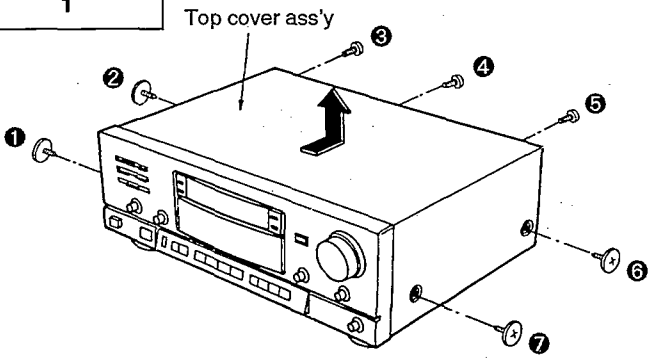
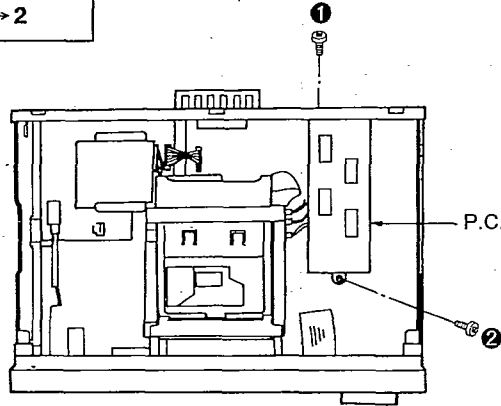
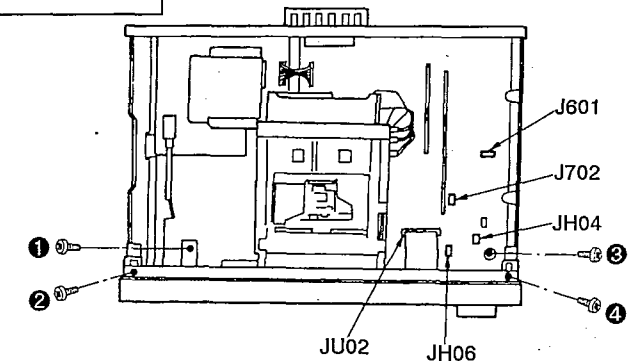
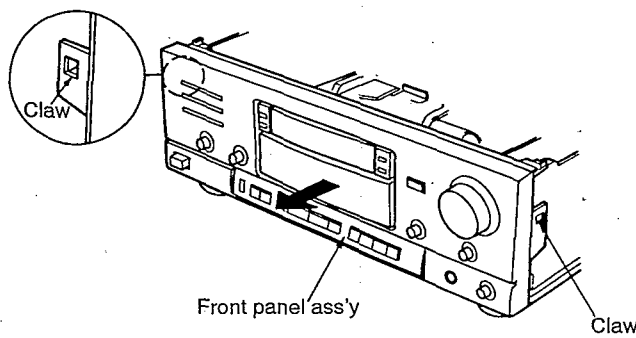
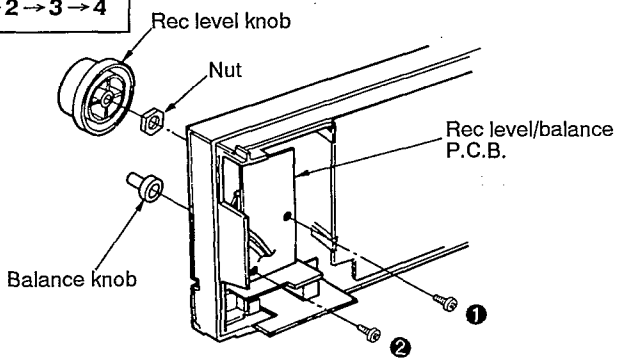
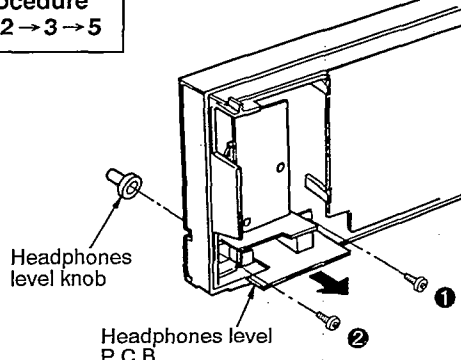
<p>Ref.No. 1</p>	<p>Removal of the top cover ass'y</p>	<p>Ref.No. 2</p>	<p>Removal of the P.C.B. cover</p>
<p>Procedure 1</p>	 <p>Top cover ass'y</p> <ol style="list-style-type: none"> 1. Remove the 7 screws(①~⑦). 2. Remove the top cover ass'y in the direction of arrow. 	<p>Procedure 1→2</p>	 <p>P.C.B.cover</p> <ul style="list-style-type: none"> • Remove the 2 screws(①, ②).
<p>Ref.No. 3</p>	<p>Removal of the front panel ass'y</p>	<p>Ref.No. 5</p>	<p>Removal of the headphones level P.C.B.</p>
<p>Procedure 1→2→3</p>	 <p>J601 J702 JH04 JU02 JH06</p> <ol style="list-style-type: none"> 1. Remove the 5 connectors(JU02,JH04,JH06,J601,J702). 2. Remove the 4 screws(①~④). 	<p>Procedure 1→2→3→5</p>	 <p>Claw Front panel ass'y Claw</p> <ol style="list-style-type: none"> 3. Remove the 2 claws. 4. Remove the front panel ass'y in the direction of arrow.
<p>Ref.No. 4</p>	<p>Removal of the rec level/balance P.C.B.</p>	<p>Ref.No. 5</p>	<p>Removal of the headphones level P.C.B.</p>
<p>Procedure 1→2→3→4</p>	 <p>Rec level knob Nut Rec level/balance P.C.B. Balance knob</p> <ol style="list-style-type: none"> 1. Pull out the rec level knob and balance knob. 2. Remove the nut. 3. Remove the 2 screws(①, ②). 	<p>Procedure 1→2→3→5</p>	 <p>Headphones level knob Headphones level P.C.B.</p> <ol style="list-style-type: none"> 1. Pull out the headphones level knob. 2. Remove the 2 screws(①, ②). 3. Remove the headphones level P.C.B. in the direction of arrow.

Ref.No. 6 **Removal of the operation P.C.B.**

Procedure
1 → 2 → 3 → 6

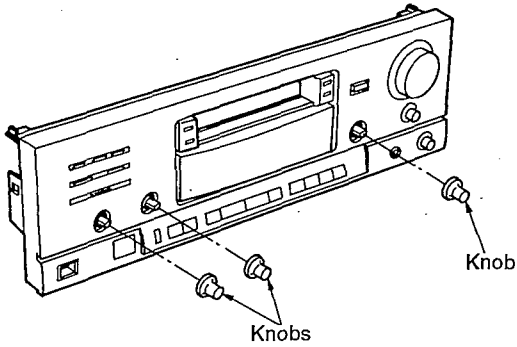

1. Remove the 3 knobs.

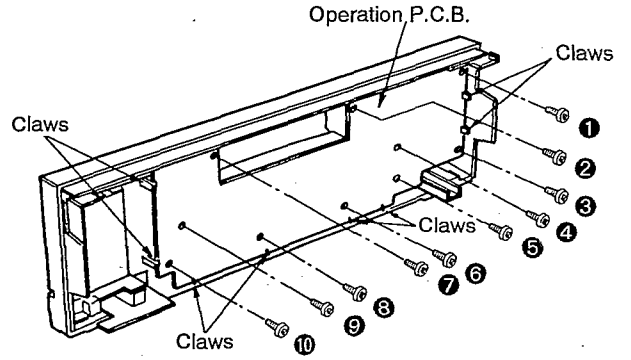

2. Remove the 10 screws (① ~ ⑩).
3. Release the 8 claws.

Ref.No. 7 **Removal of the loading unit**

Procedure
1 → 2 → 3 → 7

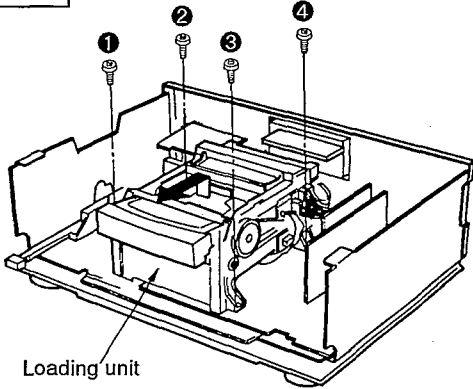

1. Remove the 4 screws (① ~ ④).
2. Remove the loading unit in the direction of arrow.

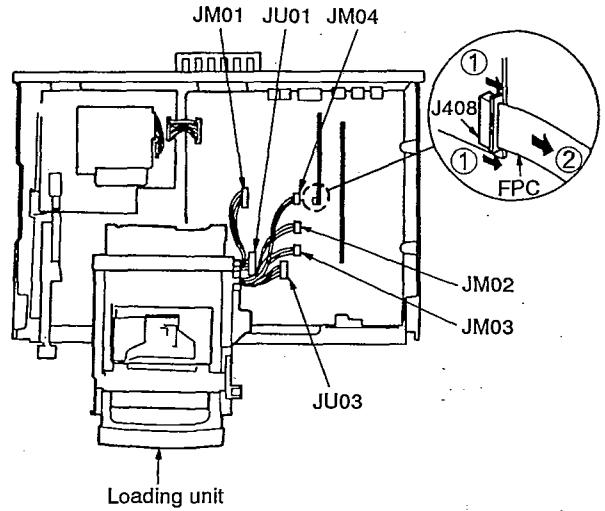

3. Remove the 7 connectors (JM01, JU03, JM04, JM02, JM03, JU01, J408).

Ref.No. 8 **Removal of the AD/DA converter P.C.B.**

Procedure
1 → 2 → 8

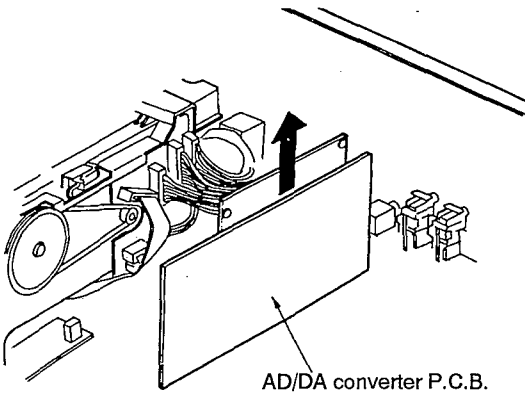

• Remove the AD/DA converter P.C.B. in the direction of arrow.

Ref.No. 9 **Removal of the PASC digital P.C.B.**

Procedure
1 → 2 → 9

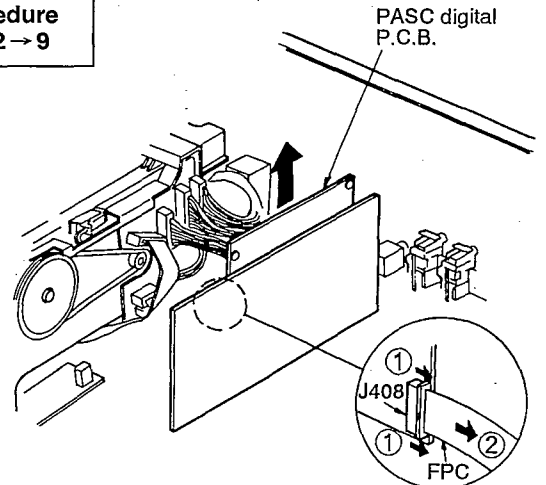

1. Remove the 1 connector (J408).
2. Remove the PASC digital P.C.B. in the direction of arrow.

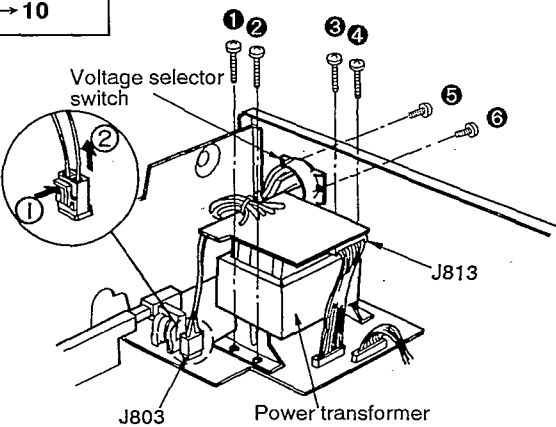
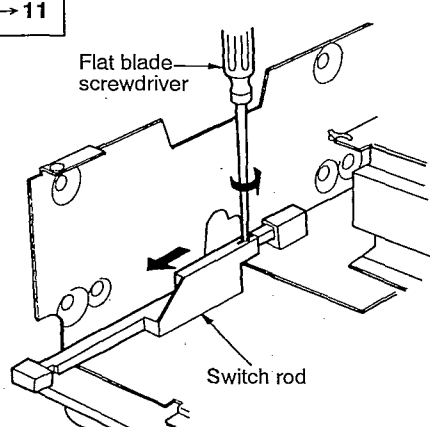
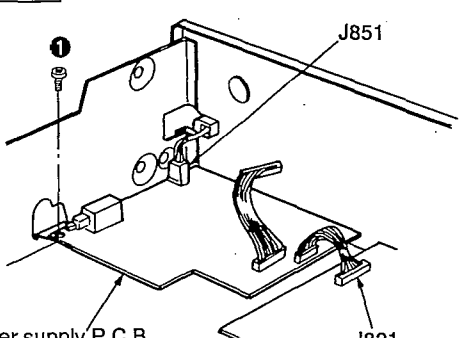
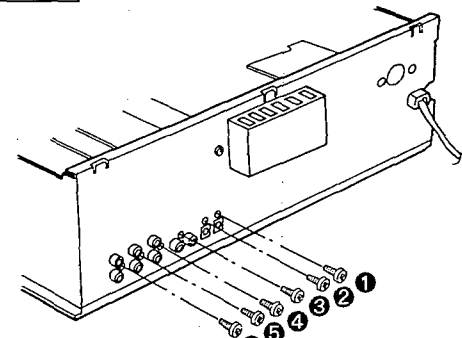
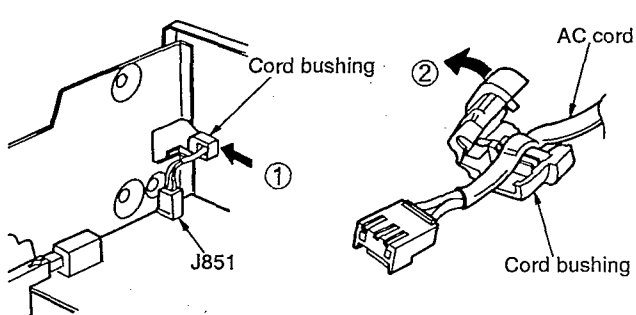
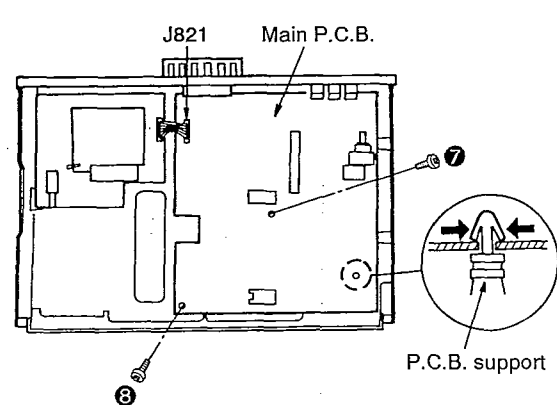
<p>Ref.No. 10</p>	<p>Removal of the power transformer and voltage selector switch</p>	<p>Ref.No. 11</p>	<p>Removal of the switch rod</p>
<p>Procedure 1 → 10</p>	 <p>1. Remove the 2 connectors(J803,J813). 2. Remove the 6 screws(①~⑥).</p>	<p>Procedure 1 → 2 → 3 → 11</p>	 <p>• Pull the switch rod with twisting the slots of the ends of the switch rod by flat blade screwdriver.</p>
<p>Ref.No. 12</p>	<p>Removal of the power supply P.C.B.</p>	<p>Ref.No. 13</p>	<p>Removal of the main P.C.B.</p>
<p>Procedure 1 → 2 → 3 → 10 → 11 → 12</p>	 <p>1. Remove the 1 screw(①). 2. Remove the 2 connectors(J821,J851).</p>	<p>Procedure 1 → 2 → 3 → 7 → 8 → 9 → 13</p>	 <p>1. Remove the 6 screws(①~⑥).</p>
<p>Ref.No. 14</p>	<p>Removal of the AC cord</p>		
<p>Procedure 1 → 14</p>	 <p>1. Remove the 1 connector(J851). 2. Remove the cord bushing in the direction of arrow ①. 3. Remove the cord bushing in the direction of arrow ②.</p>		 <p>2. Remove the 1 connector(J821). 3. Remove the 2 screws(⑦, ⑧). 4. Remove the P.C.B. support.</p>

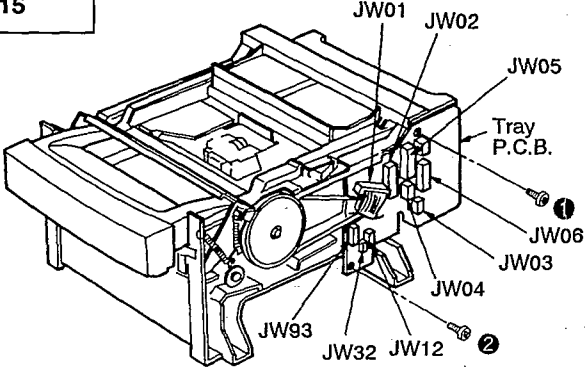
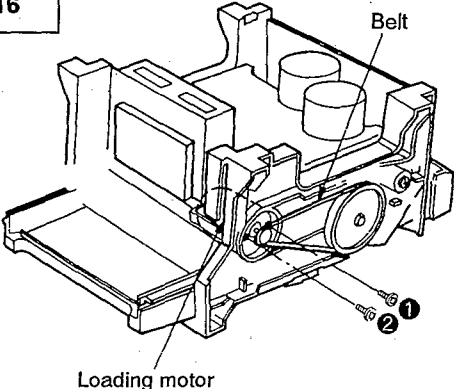
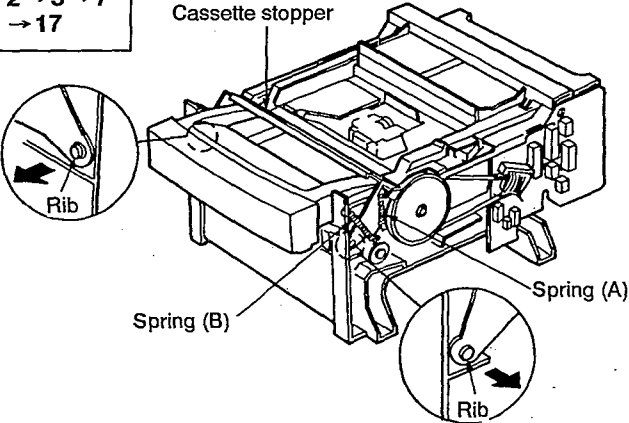
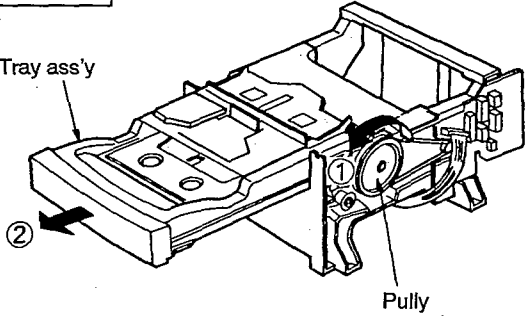
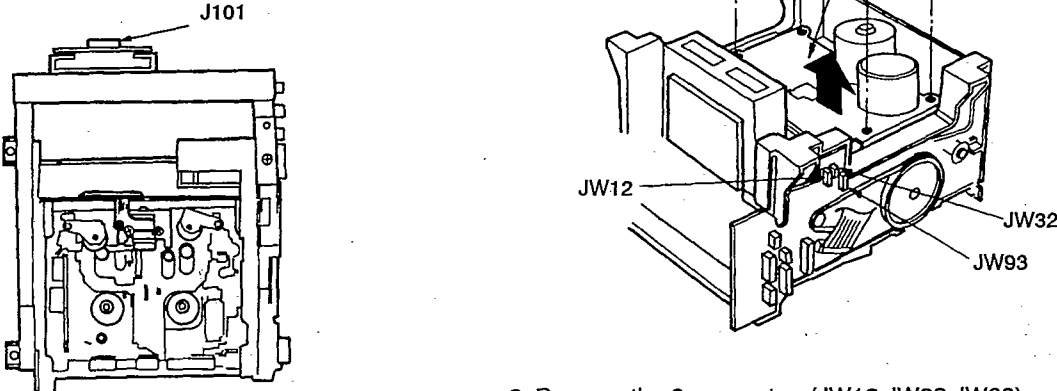
<p>Ref.No. 15</p>	<p>Removal of the tray P.C.B.</p>	<p>Ref.No. 16</p>	<p>Removal of the loading motor</p>
<p>Procedure 1→2→3→7 →15</p>	 <p>1. Remove the 9 connectors(JW01,JW02,JW03,JW04,JW05, JW06,JW12,JW32,JW93). 2. Remove the 2 screws (①,②).</p>	<p>Procedure 1→2→3→7 →15→16</p>	 <p>1. Remove the belt. 2. Remove the 2 screws (①,②).</p>
<p>Ref.No. 17</p>	<p>Removal of the cassette stopper</p>	<p>Ref.No. 18</p>	<p>Removal of the tray ass'y</p>
<p>Procedure 1→2→3→7 →17</p>	 <p>1. Remove the spring (A) and spring (B). 2. Remove the ribs in the direction of arrow.</p>	<p>Procedure 1→2→3→7 →17→18</p>	 <p>1. Roll the pulley in the direction of arrow ①, and draw out the tray. 2. Remove the tray in the direction of arrow ②.</p>
<p>Ref.No. 19</p>	<p>Removal of the mechanism unit</p>	 <p>2. Remove the 3 connectors(JW12,JW32,JW93). 3. Remove the 4 screws(①~④). 4. Remove the mechanism unit in the direction of arrow.</p>	
<p>Procedure 1→2→3→7 →17→18→19</p>	<p>1. Remove the 1 connector(J101).</p>		

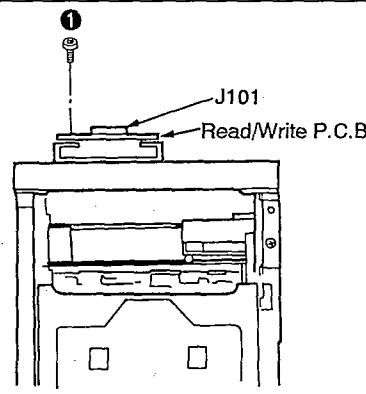
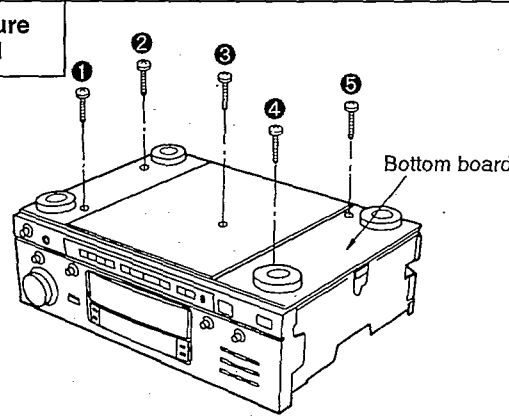
Ref.No. 20	Removal of the Read/Write P.C.B.	Ref.No. 21	Removal of the bottom board
Procedure 1 → 2 → 3 → 7 → 17 → 18 → 20	 <p>1. Remove the 1 connector(J101). 2. Remove the 1 screws(①).</p>	Procedure 1 → 21	 <p>• Remove the 5 screws(①~⑤).</p>

HEAD ASS'Y REPLACEMENT

Cautions:

1. Be sure to wear a grounding wrist band whenever you touch the head assemblies.(RFKZ0036)(See page 13.)
2. When removal the "Head Ass'y" use a unmagnetized adjusting screwdriver.(RFKZ0037)(See page 13.)

DISASSEMBLY INSTRUCTION

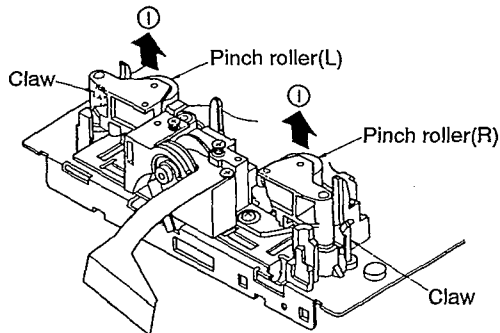

1. Release the 2 claws and remove the Pinch roller(L),(R) in the direction of arrow ①.

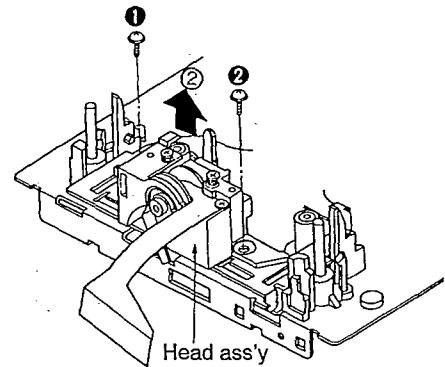

2. Remove the 2 screws(①,②).
3. Remove the head ass'y in the direction of arrow ②.

REASSEMBLY INSTRUCTION

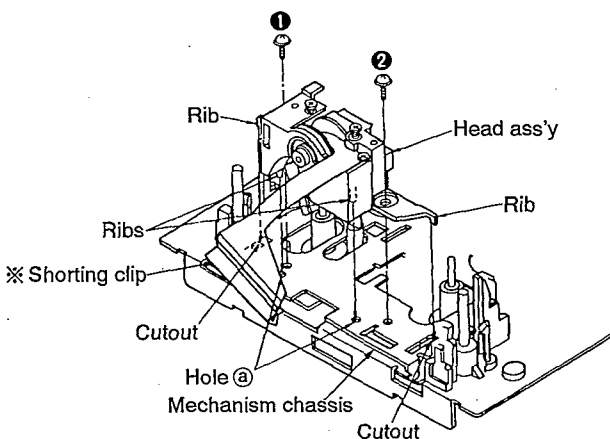

1. Align the 4 ribs of head ass'y to the two holes @ and two cutouts in the mechanism chassis.
2. Fix the 2 screws(①,②) to the head ass'y.

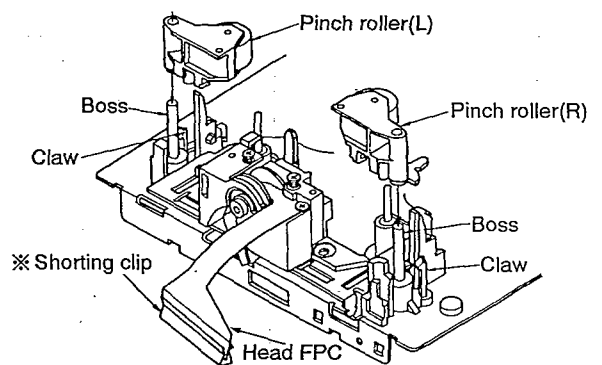

3. Fix the 2 Pinch roller(L),(R) to each boss on the mechanism chassis.
(Press the pinch rollers until it is secured by the claw on the mechanism chassis.)

- ※ • Only remove the shorting clip on the head FPC if the Read/Write P.C.B. connector (J101) is connected.
- After the shorting clip is removed, make connection to the connector (J101) as soon as possible.

OPERATIONAL CHECKING PROCEDURE

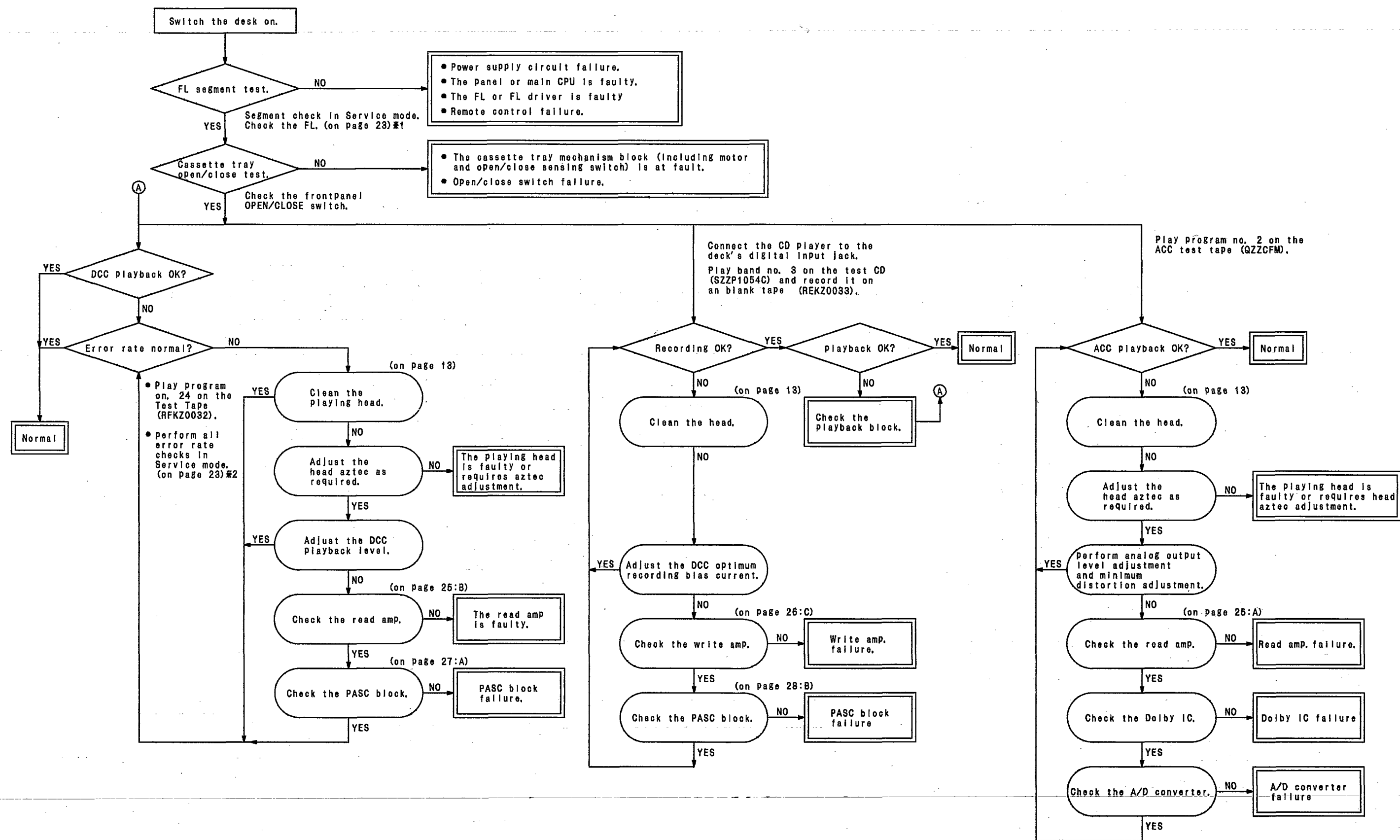

MECHANISM BLOCK CHECK

(Remount on defective mechanism block. Connect extension cords to pins 9, 10, and 11 and connect extension FPC.)

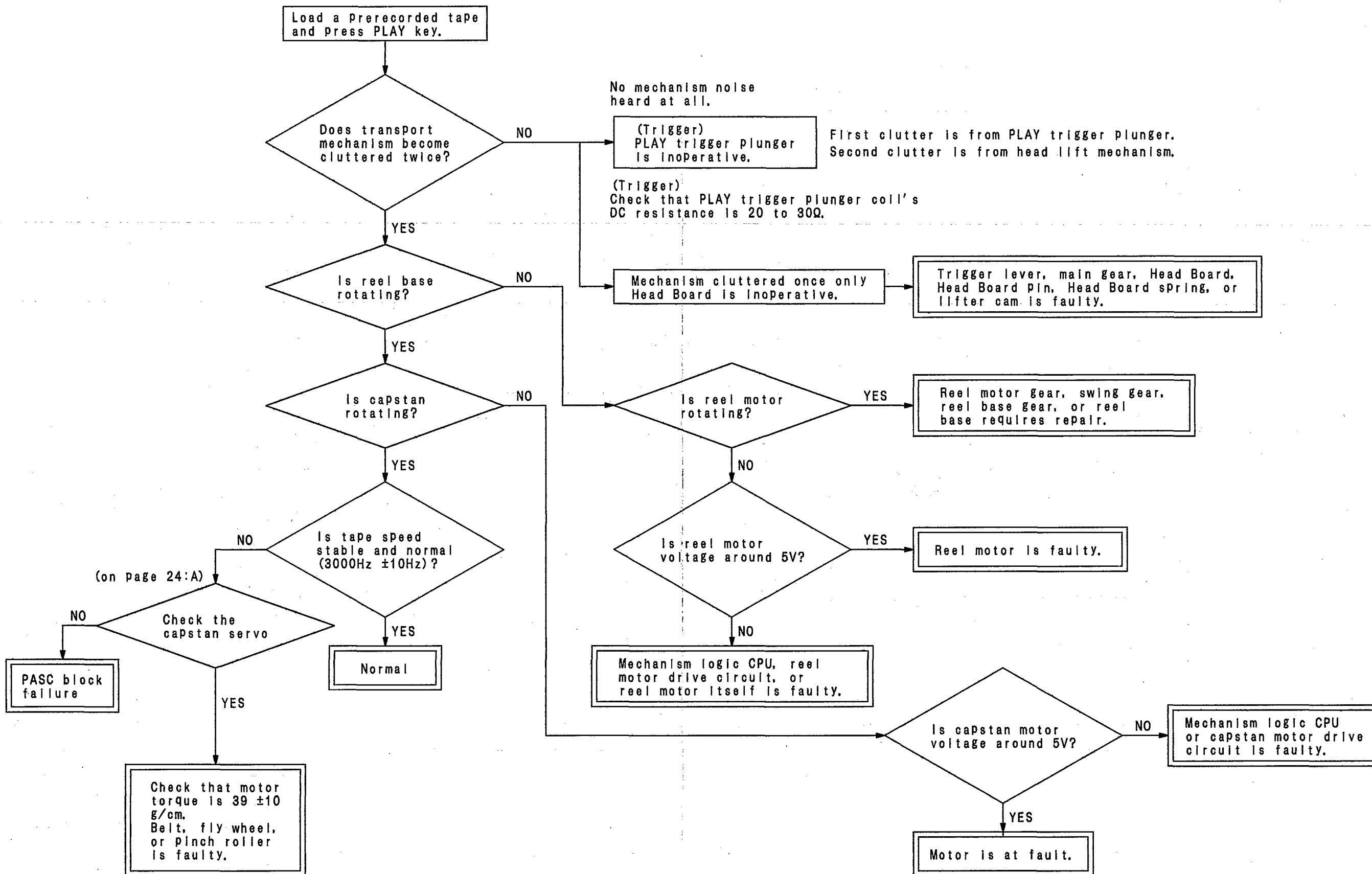

HOW TO USE "SERVICE MODE"

Test procedure by function of "Service Mode".

This unit provides "Service Mode" function by which the segment test, FL test (*1) and the "ALL ERROR RATE" inspection (*2) can be performed.

- *1
- Setting at Service Mode**
To select Service mode, switch on the unit while holding down the STOP and PLAY keys.
 - Segment Test**
The following characters are displayed in sequence

SERVICE MODE ' + ' + - , 1
 0123456789 3 = ε ' 7
 ABCDEFGHIJKLMNOPQRSTUVWXYZ
 - A ~ Z

 (Display in alphabetical order)
 - FL Test**
Press the COUNTER key
All FL segments are lit up and the PLAY (green) and REC (red) LEDs on the operation panel, come on.

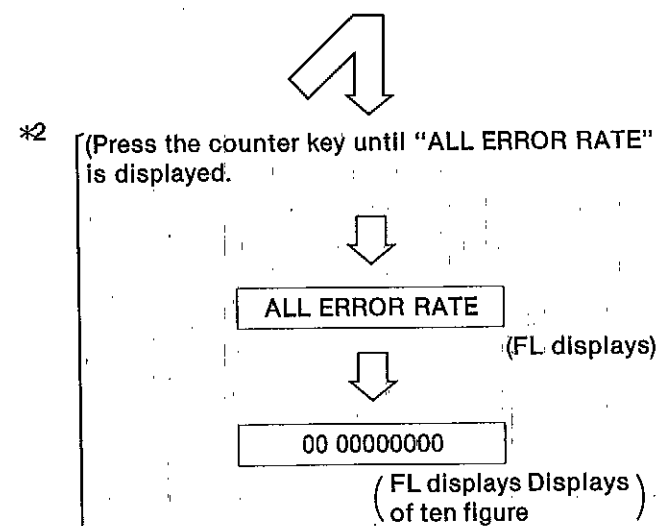

Pass/Reject Condition from All Error Rate

Program to play in DCC test tape

Display	Condition	Remedy
"00000000" is constantly displayed for all tracks.	Normal (OK)	—
"01101000" is momentarily displayed for any one to three tracks (or more).	Normal (OK)	—
"11111111" is constantly displayed for one to three tracks (or more).	Error	Clean head with alcohol. (on page 13.) ↓ Check playback signal envelope at J103-pin 7. ↓ Adjust DCC playback level if the envelope amplitude (Vp-p) is too small.
"11111111" is constantly displayed for all tracks.	Error	If the envelope amplitude is not at 12Vp-p ± 100 mV, a problem exists in the head or read amplifier. ↓ Check head assembly.
"FFFFFFF" is constantly displayed for all tracks.	Error	If the head assembly is normal, the read amplifier is most likely at fault. Refer to the content of "Read/Write P.C.B. check" on pages 25, 26.

ABOUT THE OPERATIONAL CHECKING POINTS

Capstan Servo Check

A) DCC Playback System

- Connect an oscilloscope to J411 pin 3 (motor speed TP) on the PASC digital P.C.B. as shown in the figure below (connect the scope's ground lead to the chassis ground).
- Load a DCC music tape (RFKZ0034) into the unit under test and put the unit in PLAY mode. When the capstan servo is locked, a 47 Hz square wave with a duty ratio variation of less than 0.5 μs will be observed on the scope (see Fig. 1). Unlock the servo and verify that the muting function is active.

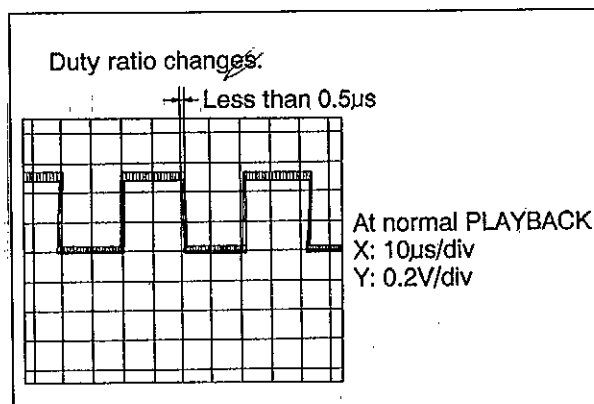

Fig. 1

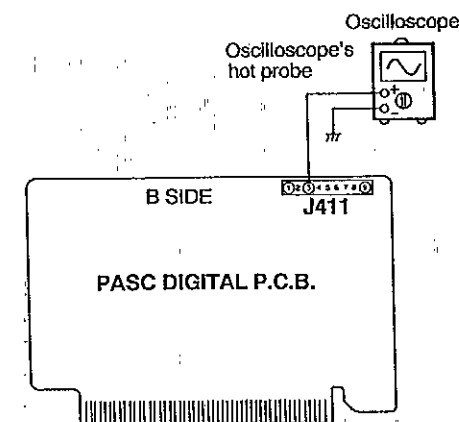

Fig. 2

B) DCC Record System and ACC Playback System

- Set up the unit as described in paragraph 1 above.
- Load a DCC blank tape (RFKZ0033) into the unit under test and put the unit in REC mode. Verify that a continuous 47 Hz square wave with a 50 percent duty ratio is observed on the scope (see Fig. 3). This is the normal result. Also verify that the same waveform is observed when a prerecorded ACC tape is played.

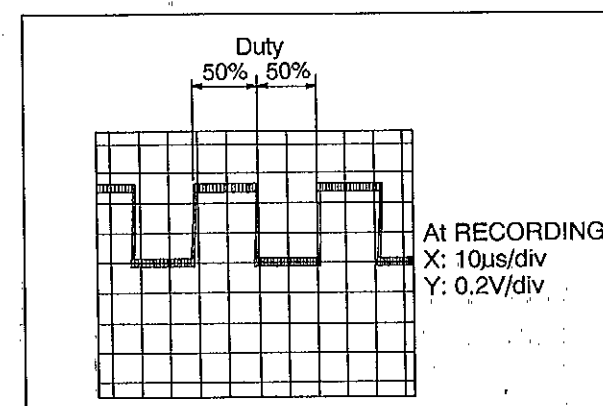

Fig. 3

Read/Write P.C.B. Check

A) ACC Playback System

- Connect an oscilloscope to J103 pin 18 (analog L-channel) or 16 (analog R-channel) on the Read/Write P.C.B. (connect the probe's ground lead to the chassis ground).
- Play a prerecorded ACC tape.
- Verify that the waveform changes as shown below when the unit is switched from STOP mode to PLAY mode.

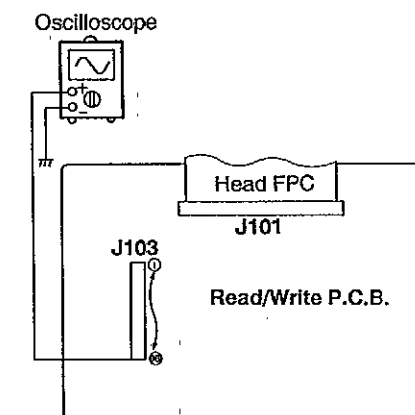

Fig. 4

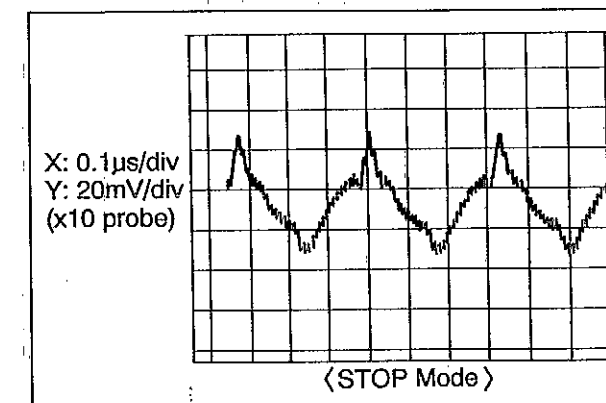

Fig. 5

Approx. 3MHz in STOP mode
An AC bias is applied to suppress 600mVp-p noise inherent to the MR head.

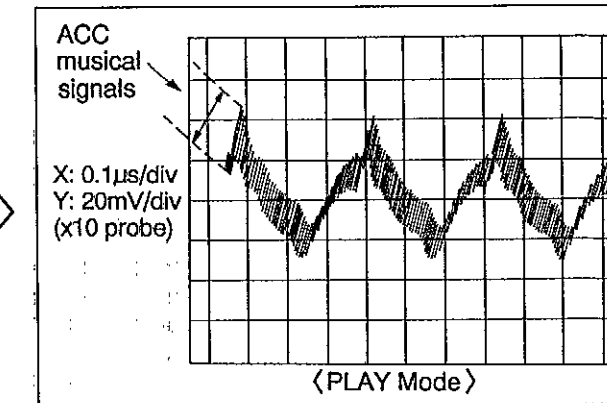

Fig. 6

During playback musical signals are superimposed on the AC bias.

B) DCC Playback System

- Connect a dual-beam oscilloscope's CH. 1 probe to J103 pin 9 (RD Clock) on the Read/Write P.C.B. (connect the probe's ground lead to the chassis ground).
- Connect the scope's CH. 2 probe to J103 pin 11 (RD Sync).
- Play a DCC music tape (RFKZ0034).
- Verify that the waveform shown below is observed on the scope.

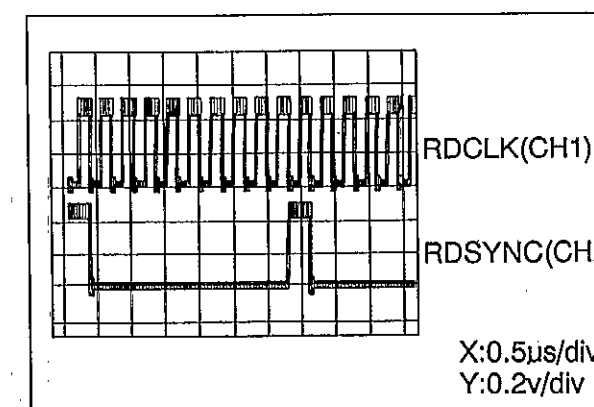

Fig. 7

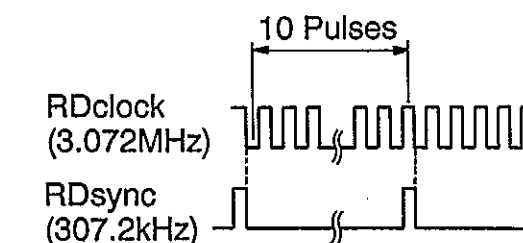

Fig. 8

5. Connect an oscilloscope's CH. 1 probe to J103 pin 7 (RD Mux) on the Read/Write P.C.B. (connect the probe's ground lead to the chassis ground).
6. Connect the scope's CH. 2 probe to J103 pin 11 (RD Sync).
7. Play a DCC music tape (RFKZ0034).
8. Verify that the waveform shown below is observed on the scope.

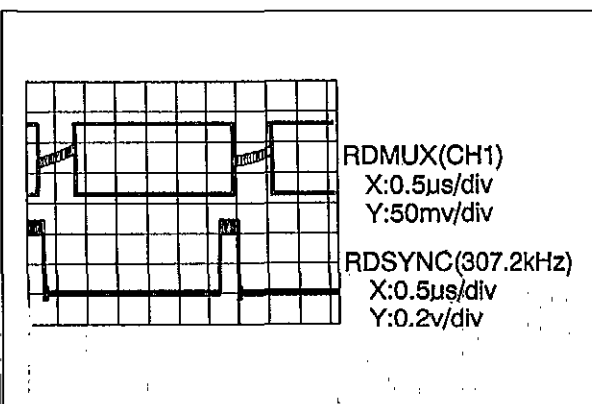

Fig. 9

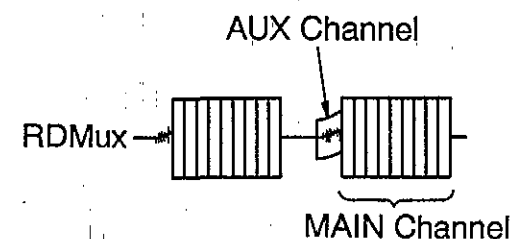

Fig. 10

PASC Digital P.C.B. Check

A) Play Mode Check

- Checking the Input Signal Waveforms
 1. Play program no. 34 on the Test Tape (RFKZ0032). Connect an oscilloscope to J408 pin 7 on the PASC Digital P.C.B. and check for the following input signal waveforms (connect the scope's ground lead to the chassis ground).

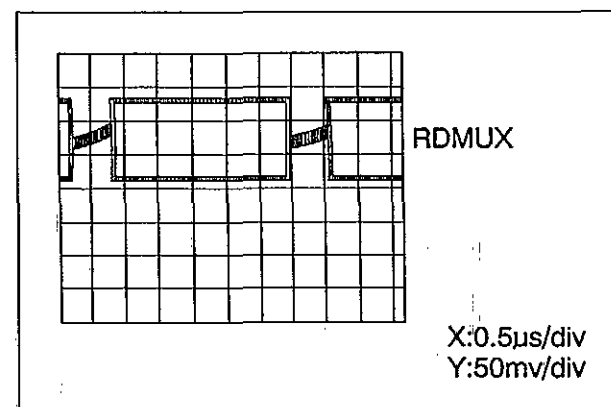

Fig. 13



Fig. 14

- Checking the Output Signal Waveforms

1. Check the output waveforms at pin 42 (connect to the scope's ch. 1 probe) and pin 50 (connect to the scope's ch. 2 probe) of connector J421, which connects the PASC Digital P.C.B. to the Main P.C.B.
2. Play program no. 34 on the Test Tape (RFKZ0032) and observe the output signal waveforms. Play program no. 47 on the same tape and check to make sure that the following output waveforms are observed.

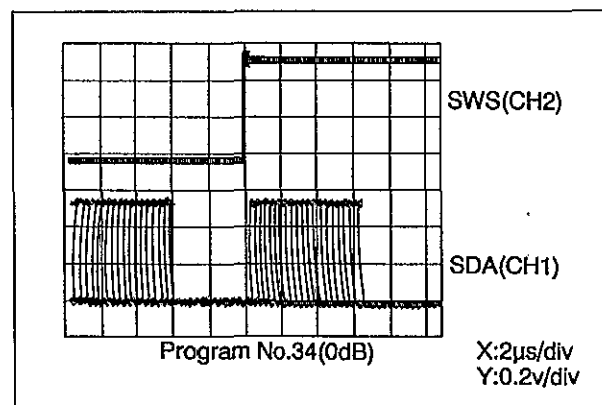

Fig. 15

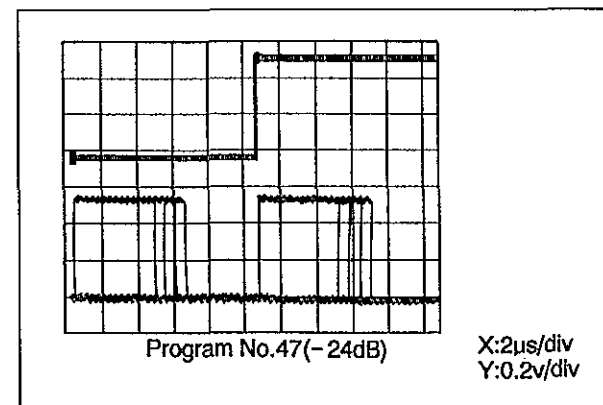

Fig. 16

The playback system is functioning normally if the specified input and output waveforms are obtained at the test points.

B) Recording Mode Check

Feed the CD player output to the DIGITAL REC IN/COAXIAL jack on the DCC deck.

- Checking the Input Signal Waveforms

1. Connect the oscilloscope to the same test points as those used to check the playback output signal.
2. Load an DCC blank tape (RFKZ0033) into the DCC deck. Play Track 1 and 3 on the test CD (SZZP1054C) and place the deck in REC mode to record the CD test programs.
3. Check for the following input signal waveforms at the test points.

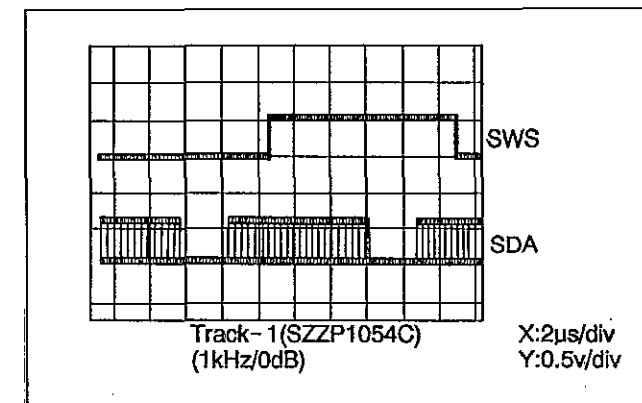

Fig. 17

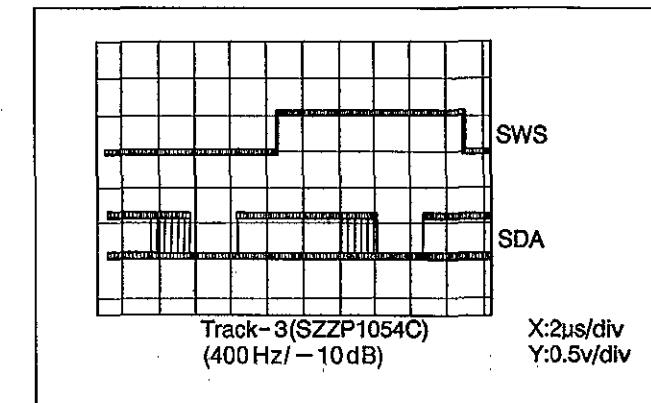

Fig. 18

- Checking the Output Signal Waveforms

1. Connect an oscilloscope to J408 pin 3 on the PASC Digital P.C.B. and check for the following output signal waveforms (connect the scope's ground lead to the chassis ground).

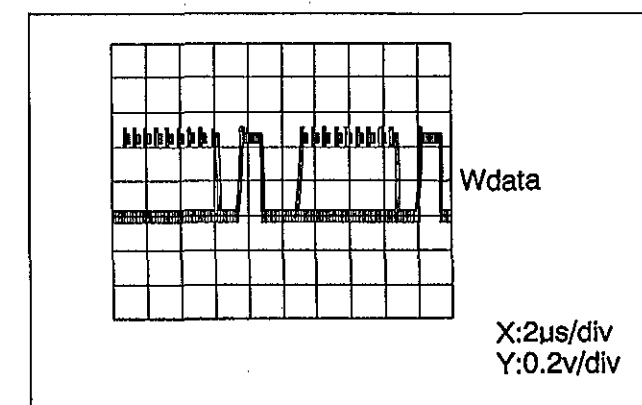

Fig. 19



Fig. 20

The recording system is functioning normally if the specified input signal waveforms are obtained at the test point.

C) DCC Recording System

9. Connect the dual-beam oscilloscope's CH. 1 probe to J103 pin 5 (WCLK) on the Read/Write P.C.B. (connect the probe's ground lead to the chassis ground).
10. Connect the scope's CH. 2 probe to J103 pin 3 (WDATA).
11. Play a DCC blank tape (RFKZ0033). Verify that the waveform shown next page is observed on the scope.

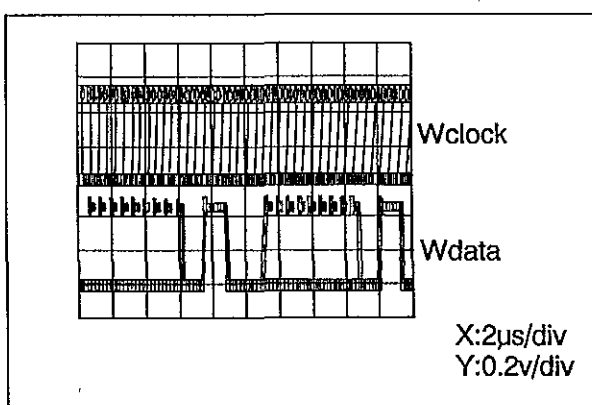

Fig. 11

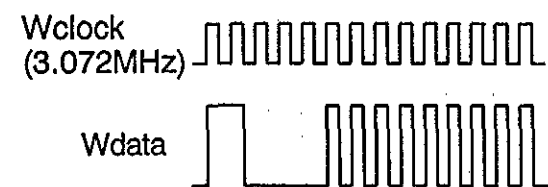
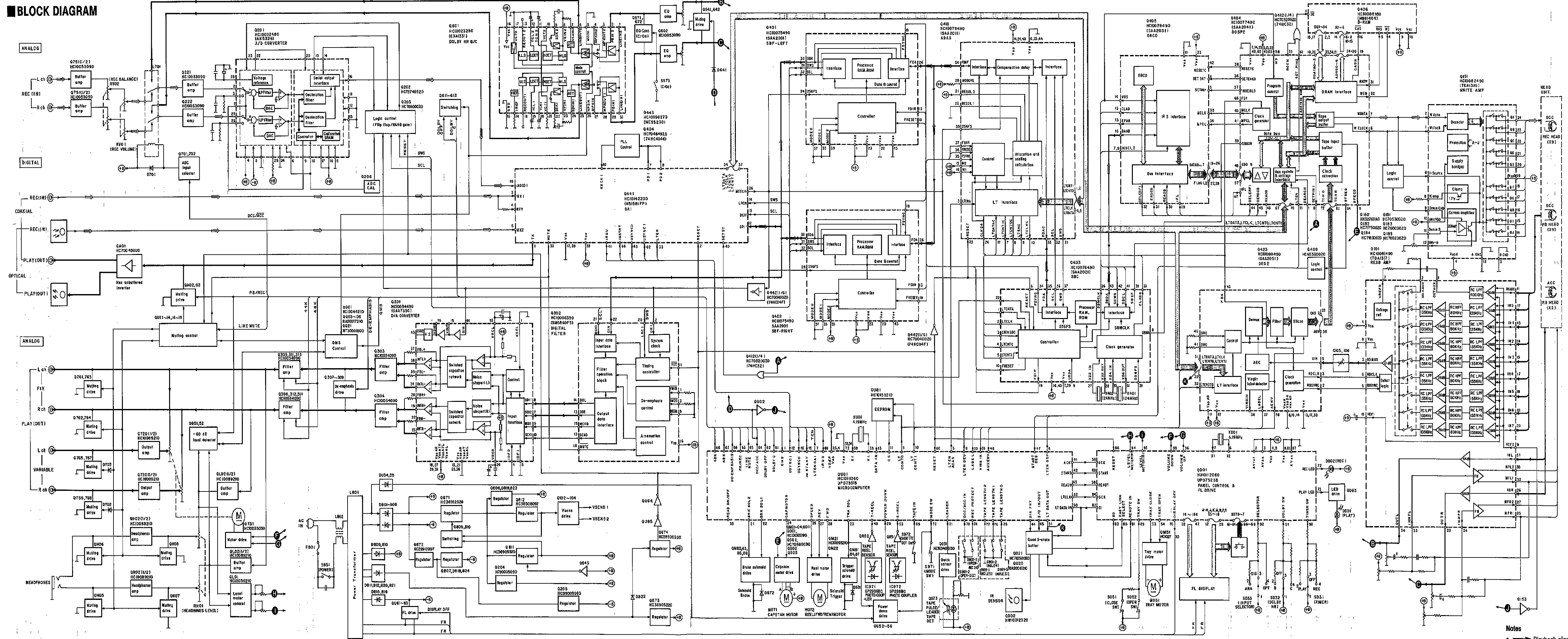

Fig. 12

- If adjustment failed, it is most probable that —
- (1) Q101, Q105, Q106, or Q151 on the Read/Write P.C.B. (or any combination there of) is defective.
 - (2) The head is contaminated. Clean the head with alcohol. (Follow the same cleaning procedure as for ACC decks.)

BLOCK DIAGRAM



Notes

- ▶ Playback signal
- ◀ Recording signal

SCHEMATIC DIAGRAM

(Parts list on pages 67-74.)

(This schematic diagram may be modified at any time with development of new technology.)

- Note 1:
- J091 : Voltage selector in "240V" position. (110V ↔ 120V ↔ 240V ↔ 220V)
 - S851 : Power switch in "on" position (POWER/ OFF = ON).
 - Resistance are in ohms (Ω), 1/4 watt unless specified otherwise. 1K=1,000 (K), 1M=1,000K (M)
 - Capacity are in micro-farads (μF) unless specified otherwise.
 - All voltage values shown in circuitry are under no signal condition and playback mode with volume control at minimum position otherwise specified.
 - ().....Voltage values at record mode. For measurement us EVM.
 - Important safety notice
- Components identified by Δ mark have special characteristics important for safety. When replacing any of these components, use only manufacturer's specified parts.
- (---+B---) Indicates +B (bias).
 - (---B---) Indicates -B (bias).
 - (→) Indicates the flow of the playback signal.
 - (→) Indicates the flow of the record signal.

- Caution!
- IC and LSI are sensitive to static electricity. Secondary trouble can be prevented by taking care during repair.
- Cover the parts boxes made of plastics with aluminum foil.
 - Ground the soldering iron.
 - Put a conductive mat on the work table.
 - Do not touch the legs of IC or LSI with the fingers directly.

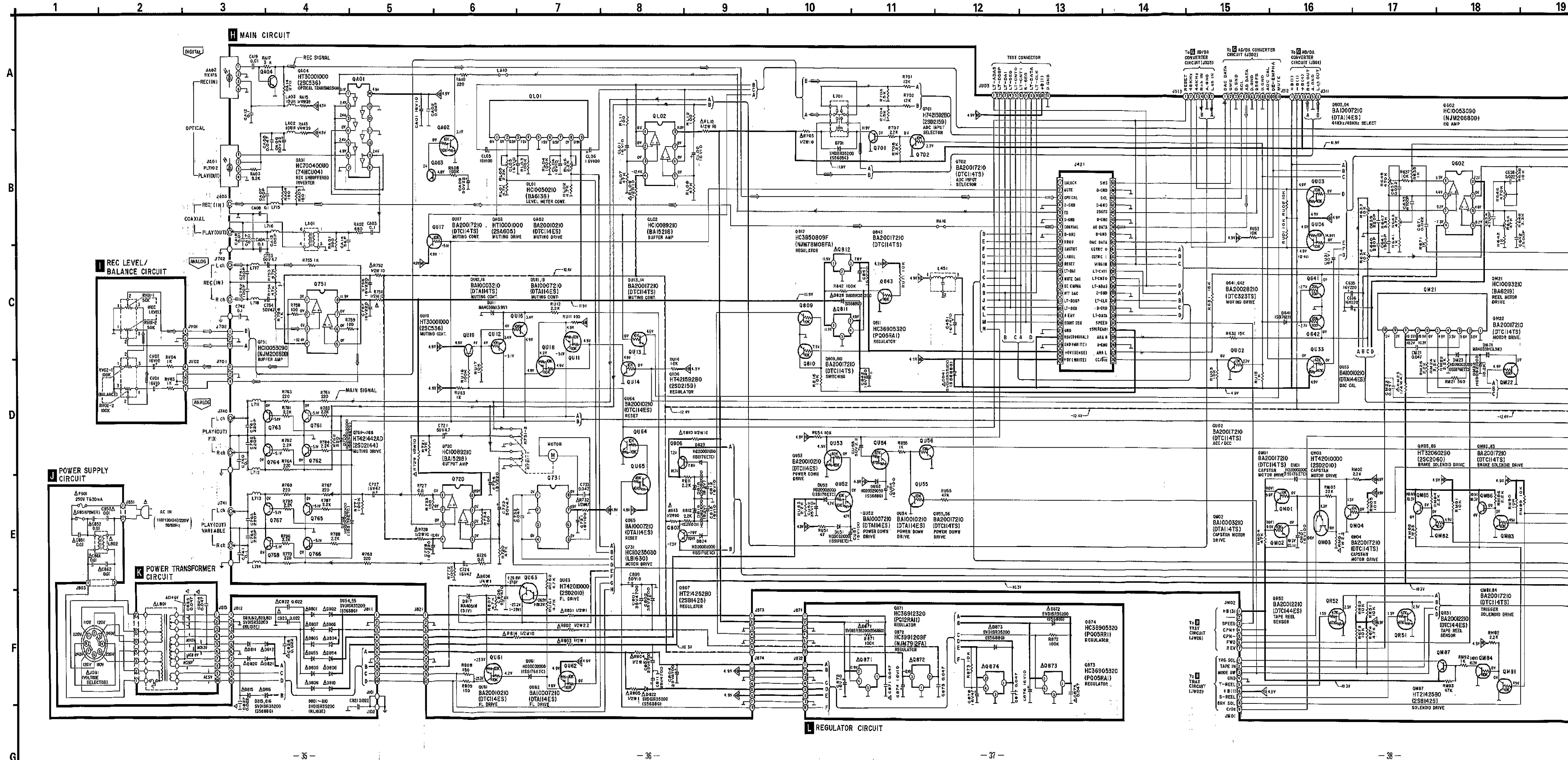

Note 3:

- S051 : Cassette tray close detection switch.
 - S052 : Cassette tray open detection switch.
 - S901-1~S901-3: Tape playing time detection switch.
 - S902-1 : DCC/ACC Tape detection switch in "DCC" position.
 - S902-2 : DCC Rec detection switch in "DCC REC" position.
 - S971 : Mechanism Play/Stop Mode switch in "stop" position.
 - S972 : Cassette half detection switch.
 - S973 : ATS (Normal•CrO₂/Metal) selector switch in "normal" position.
 - SD01 : Repeat switch (REPEAT).
 - SD02 : Tape travel selector switch (SIDE A/B).
 - SD03 : Rewind switch (REW).
 - SD04 : Fastforward switch (FF).
 - SD05 : Skip switch (SKIP).
 - SD06 : Skip switch (SKIP).
 - SD07 : Play switch (PLAY).
 - SD08 : Stop switch (STOP).
 - SD09 : Append switch (APPEND).
 - SD10 : Renumber switch (RENUMBER).
 - SD11 : MKR erase switch (MKR ERASE).
 - SD12 : Next MKR write switch (NEXT MKR WRITE).
 - SD13 : Reverse MKR write switch (REVERSE MKR WRITE).
 - SD14 : Start MKR write switch (START MKR WRITE).
 - SD15 : Pause switch (PAUSE).
 - SD16 : Record switch (REC).
 - SD17 : Cassette tray open/close switch (OPEN/CLOSE).
 - SD19 : Counter reset switch (COUNTER RESET).
 - SD20 : Text information selector switch (TEXT).
 - SD21 : Counter selector switch (COUNTER).
 - SD23 : Auto start MKR switch (AUTO START MKR).
 - SD24 : Recording mute switch (AUTO REC MUTE).
 - SD31 : Timer switch "off" position (TIMER).
 - SD32 : Dolby NR selector switch (DOLBY NR).
 - SD33 : Input selector switch (INPUT SELECTOR).
- Resistance are in ohms (Ω), 1/4 watt unless specified otherwise.
 1K=1,000 (Ω), 1M=1,000k (Ω)
 Capacity are in micro-farads (μF) unless specified otherwise.
 All voltage values shown in circuitry are under no signal condition and playback mode with volume control at minimum position otherwise specified.
 ()..... Voltage values at record mode.
 For measurement us EVM.
- Important safety notice
 Components identified by Δ mark have special characteristics important for safety. When replacing any of these components, use only manufacturer's specified parts.
- (---< +B >---) Indicates +B (bias).
 - (---< -B >---) Indicates -B (bias).
 - (--->---) Indicates the flow of the playback signal.
 - (---<---) Indicates the flow of the record signal.

Caution!

- IC and LSI are sensitive to static electricity. Secondary trouble can be prevented by taking care during repair.
- Cover the parts boxes made of plastics with aluminum foil.
 - Ground the soldering iron.
 - Put a conductive mat on the work table.
 - Do not touch the legs of IC or LSI with the fingers directly.

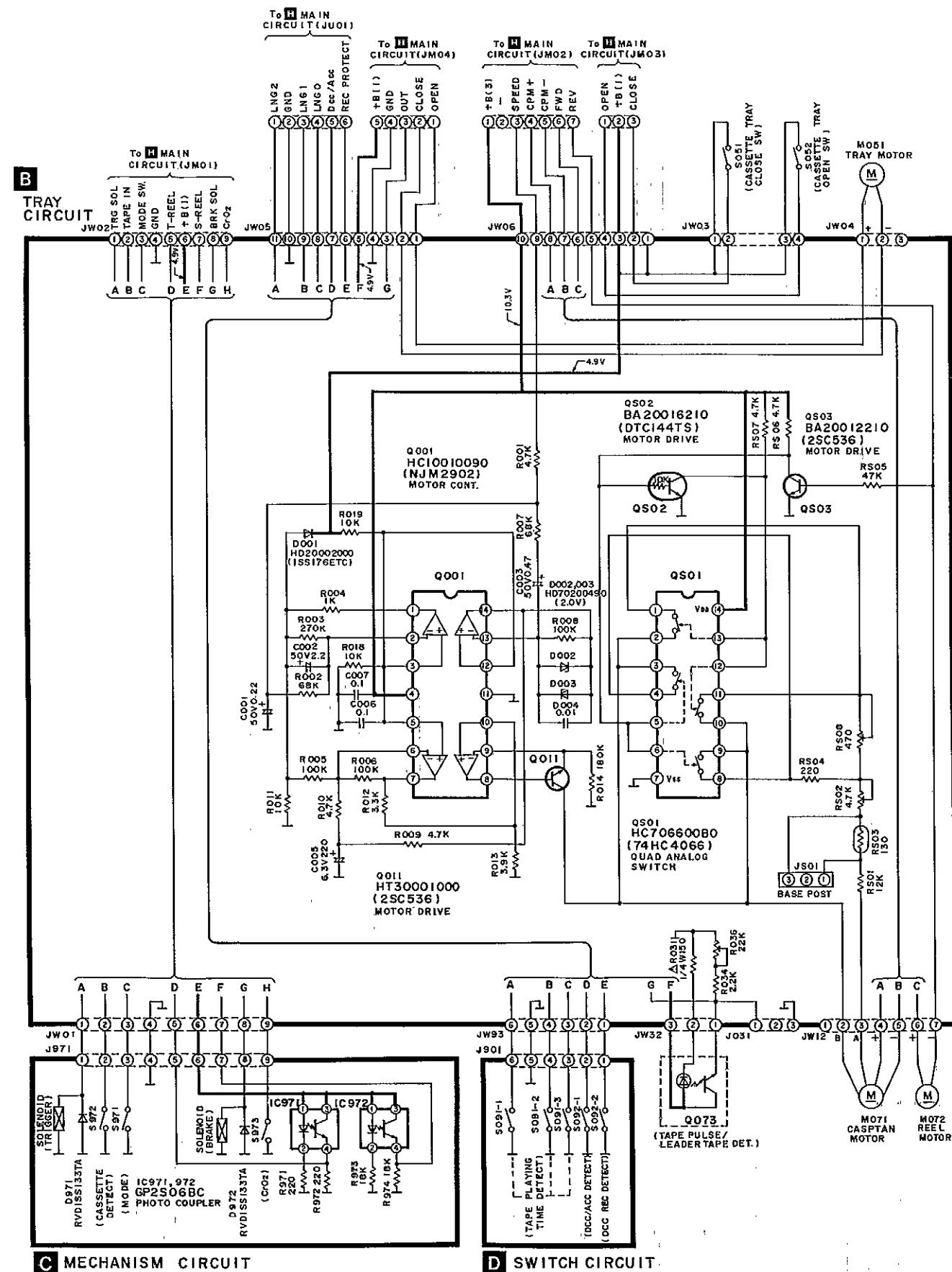

FASC DIGITAL CIRCUIT

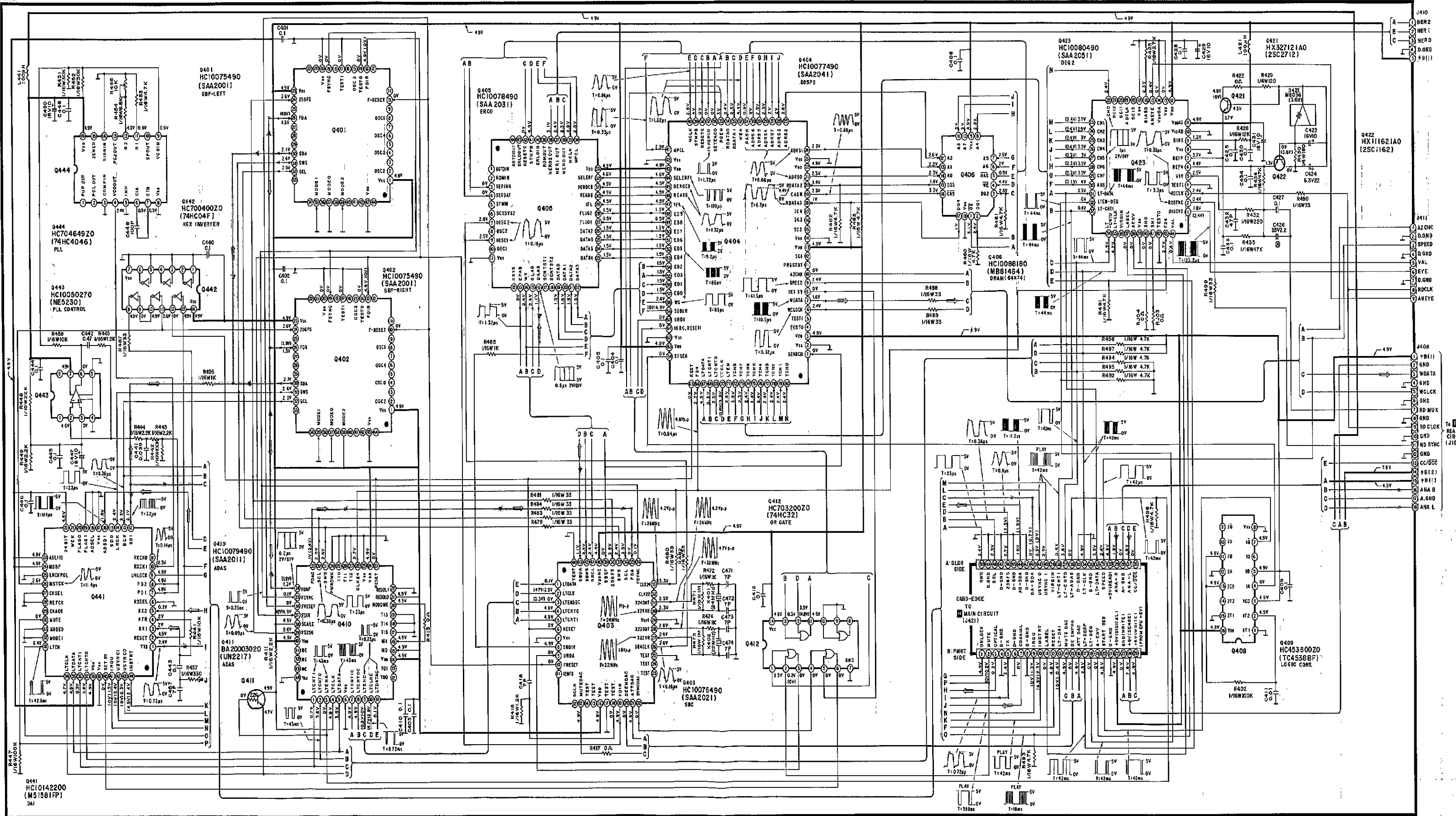

TERMINAL GUIDE OF IC'S, TRANSISTORS AND DIODES

<table border="1"> <tr><td>HC10033090</td><td>8 Pin</td><td>HC71750020</td><td>16 Pin</td></tr> <tr><td>HC10034090</td><td>8 Pin</td><td>HC71630020</td><td>16 Pin</td></tr> <tr><td>HC10050270</td><td>14 Pin</td><td>HC10008390</td><td>22 Pin</td></tr> <tr><td>HC70060020</td><td>14 Pin</td><td>HC10082490</td><td>24 Pin</td></tr> <tr><td>HC70530020</td><td>16 Pin</td><td></td><td></td></tr> </table>	HC10033090	8 Pin	HC71750020	16 Pin	HC10034090	8 Pin	HC71630020	16 Pin	HC10050270	14 Pin	HC10008390	22 Pin	HC70060020	14 Pin	HC10082490	24 Pin	HC70530020	16 Pin			<table border="1"> <tr><td>HC70000020</td><td>14 Pin</td><td>GP2806BC</td><td></td></tr> <tr><td>HC70040020</td><td>14 Pin</td><td></td><td></td></tr> <tr><td>HC45380020</td><td>16 Pin</td><td></td><td></td></tr> <tr><td>HC73740520</td><td>20 Pin</td><td></td><td></td></tr> </table>	HC70000020	14 Pin	GP2806BC		HC70040020	14 Pin			HC45380020	16 Pin			HC73740520	20 Pin																																																																
HC10033090	8 Pin	HC71750020	16 Pin																																																																																																
HC10034090	8 Pin	HC71630020	16 Pin																																																																																																
HC10050270	14 Pin	HC10008390	22 Pin																																																																																																
HC70060020	14 Pin	HC10082490	24 Pin																																																																																																
HC70530020	16 Pin																																																																																																		
HC70000020	14 Pin	GP2806BC																																																																																																	
HC70040020	14 Pin																																																																																																		
HC45380020	16 Pin																																																																																																		
HC73740520	20 Pin																																																																																																		
<table border="1"> <tr><td>HC10054490</td><td>44 Pin</td><td>HC10080490</td><td>44 Pin</td></tr> <tr><td>HC10075490</td><td>44 Pin</td><td>HC10081490</td><td>44 Pin</td></tr> <tr><td>HC10076490</td><td>44 Pin</td><td>HC10142200</td><td>44 Pin</td></tr> <tr><td>HC10078490</td><td>44 Pin</td><td>HU10112090</td><td>94 Pin</td></tr> <tr><td>HC10079490</td><td>44 Pin</td><td></td><td></td></tr> </table>	HC10054490	44 Pin	HC10080490	44 Pin	HC10075490	44 Pin	HC10081490	44 Pin	HC10076490	44 Pin	HC10142200	44 Pin	HC10078490	44 Pin	HU10112090	94 Pin	HC10079490	44 Pin			<table border="1"> <tr><td>HC80005090</td><td></td><td>HC1008180</td><td></td><td>HC10077490</td><td></td></tr> <tr><td></td><td></td><td></td><td></td><td></td><td></td></tr> </table>	HC80005090		HC1008180		HC10077490																																																																									
HC10054490	44 Pin	HC10080490	44 Pin																																																																																																
HC10075490	44 Pin	HC10081490	44 Pin																																																																																																
HC10076490	44 Pin	HC10142200	44 Pin																																																																																																
HC10078490	44 Pin	HU10112090	94 Pin																																																																																																
HC10079490	44 Pin																																																																																																		
HC80005090		HC1008180		HC10077490																																																																																															
<table border="1"> <tr><td>HC10162120</td><td>8 Pin</td><td>HC706600B0</td><td>14 Pin</td></tr> <tr><td>HC10235030</td><td>8 Pin</td><td>HC712500B0</td><td>14 Pin</td></tr> <tr><td>HC10340050</td><td>8 Pin</td><td>HC70464920</td><td>16 Pin</td></tr> <tr><td>HC10010090</td><td>14 Pin</td><td>HC10002480</td><td>28 Pin</td></tr> <tr><td>HU10111060</td><td>14 Pin</td><td>HC10023250</td><td>30 Pin</td></tr> </table>	HC10162120	8 Pin	HC706600B0	14 Pin	HC10235030	8 Pin	HC712500B0	14 Pin	HC10340050	8 Pin	HC70464920	16 Pin	HC10010090	14 Pin	HC10002480	28 Pin	HU10111060	14 Pin	HC10023250	30 Pin	<table border="1"> <tr><td>HC700400U0</td><td></td><td>HC10088210</td><td>8 Pin</td></tr> <tr><td></td><td></td><td>HC10063090</td><td>8 Pin</td></tr> <tr><td></td><td></td><td>HC70320020</td><td>14 Pin</td></tr> </table>	HC700400U0		HC10088210	8 Pin			HC10063090	8 Pin			HC70320020	14 Pin																																																																		
HC10162120	8 Pin	HC706600B0	14 Pin																																																																																																
HC10235030	8 Pin	HC712500B0	14 Pin																																																																																																
HC10340050	8 Pin	HC70464920	16 Pin																																																																																																
HC10010090	14 Pin	HC10002480	28 Pin																																																																																																
HU10111060	14 Pin	HC10023250	30 Pin																																																																																																
HC700400U0		HC10088210	8 Pin																																																																																																
		HC10063090	8 Pin																																																																																																
		HC70320020	14 Pin																																																																																																
<table border="1"> <tr><td>HC10044210</td><td></td><td>HC10083210</td><td></td><td>HW10012320</td><td></td><td>HF203722A0</td><td></td><td>HT10001030</td><td></td></tr> <tr><td>HC10050210</td><td></td><td>HC10279030</td><td></td><td></td><td></td><td></td><td></td><td>HT214252B0</td><td></td></tr> <tr><td></td><td></td><td></td><td></td><td></td><td></td><td></td><td></td><td>HT30001030</td><td></td></tr> <tr><td></td><td></td><td></td><td></td><td></td><td></td><td></td><td></td><td>HT320602B0</td><td></td></tr> <tr><td></td><td></td><td></td><td></td><td></td><td></td><td></td><td></td><td>HT421582B0</td><td></td></tr> </table>	HC10044210		HC10083210		HW10012320		HF203722A0		HT10001030		HC10050210		HC10279030						HT214252B0										HT30001030										HT320602B0										HT421582B0		<table border="1"> <tr><td>HT421442A0</td><td></td><td>HT42010000</td><td></td><td>BA10003210</td><td></td><td>BA20012210</td><td></td></tr> <tr><td></td><td></td><td></td><td></td><td>BA10007210</td><td></td><td>BA20016210</td><td></td></tr> <tr><td></td><td></td><td></td><td></td><td>BA10010210</td><td></td><td>BA20017210</td><td></td></tr> <tr><td></td><td></td><td></td><td></td><td>BA10026210</td><td></td><td>BA20028210</td><td></td></tr> <tr><td></td><td></td><td></td><td></td><td>BA20003020</td><td></td><td></td><td></td></tr> <tr><td></td><td></td><td></td><td></td><td>BA20010210</td><td></td><td></td><td></td></tr> </table>	HT421442A0		HT42010000		BA10003210		BA20012210						BA10007210		BA20016210						BA10010210		BA20017210						BA10026210		BA20028210						BA20003020								BA20010210			
HC10044210		HC10083210		HW10012320		HF203722A0		HT10001030																																																																																											
HC10050210		HC10279030						HT214252B0																																																																																											
								HT30001030																																																																																											
								HT320602B0																																																																																											
								HT421582B0																																																																																											
HT421442A0		HT42010000		BA10003210		BA20012210																																																																																													
				BA10007210		BA20016210																																																																																													
				BA10010210		BA20017210																																																																																													
				BA10026210		BA20028210																																																																																													
				BA20003020																																																																																															
				BA20010210																																																																																															
<table border="1"> <tr><td>HX108122B0</td><td></td><td>HX11621A0</td><td></td><td>HX327121A0</td><td></td><td>HX40992A0</td><td></td></tr> <tr><td></td><td></td><td></td><td></td><td></td><td></td><td></td><td></td></tr> </table>	HX108122B0		HX11621A0		HX327121A0		HX40992A0										<table border="1"> <tr><td>HD20002000</td><td></td><td>MA4039M</td><td></td><td>HZ20006020</td><td></td></tr> <tr><td>HD20029050</td><td></td><td>MA4051M</td><td></td><td></td><td></td></tr> <tr><td>HD30621000</td><td></td><td></td><td></td><td></td><td></td></tr> <tr><td>HD70203490</td><td></td><td></td><td></td><td></td><td></td></tr> <tr><td>SVD1SR35200</td><td></td><td></td><td></td><td></td><td></td></tr> <tr><td>RVD1SS133TA</td><td></td><td></td><td></td><td></td><td></td></tr> </table>	HD20002000		MA4039M		HZ20006020		HD20029050		MA4051M				HD30621000						HD70203490						SVD1SR35200						RVD1SS133TA																																																			
HX108122B0		HX11621A0		HX327121A0		HX40992A0																																																																																													
HD20002000		MA4039M		HZ20006020																																																																																															
HD20029050		MA4051M																																																																																																	
HD30621000																																																																																																			
HD70203490																																																																																																			
SVD1SR35200																																																																																																			
RVD1SS133TA																																																																																																			
<table border="1"> <tr><td>HZ30018050</td><td></td><td>H10062320</td><td></td><td>HC38905320</td><td></td><td>HC38912320</td><td></td><td>HC3890809F</td><td></td></tr> <tr><td></td><td></td><td>H10114320</td><td></td><td>HC38903320</td><td></td><td>HC38903320</td><td></td><td>HC3891209F</td><td></td></tr> </table>	HZ30018050		H10062320		HC38905320		HC38912320		HC3890809F				H10114320		HC38903320		HC38903320		HC3891209F		<table border="1"> <tr><td></td><td></td><td></td><td></td><td></td><td></td><td></td><td></td><td></td><td></td></tr> </table>																																																																														
HZ30018050		H10062320		HC38905320		HC38912320		HC3890809F																																																																																											
		H10114320		HC38903320		HC38903320		HC3891209F																																																																																											

PRINTED CIRCUIT BOARDS

A
B
C
D
E
F
G

J POWER SUPPLY P.C.B. (ZZ01D8210)

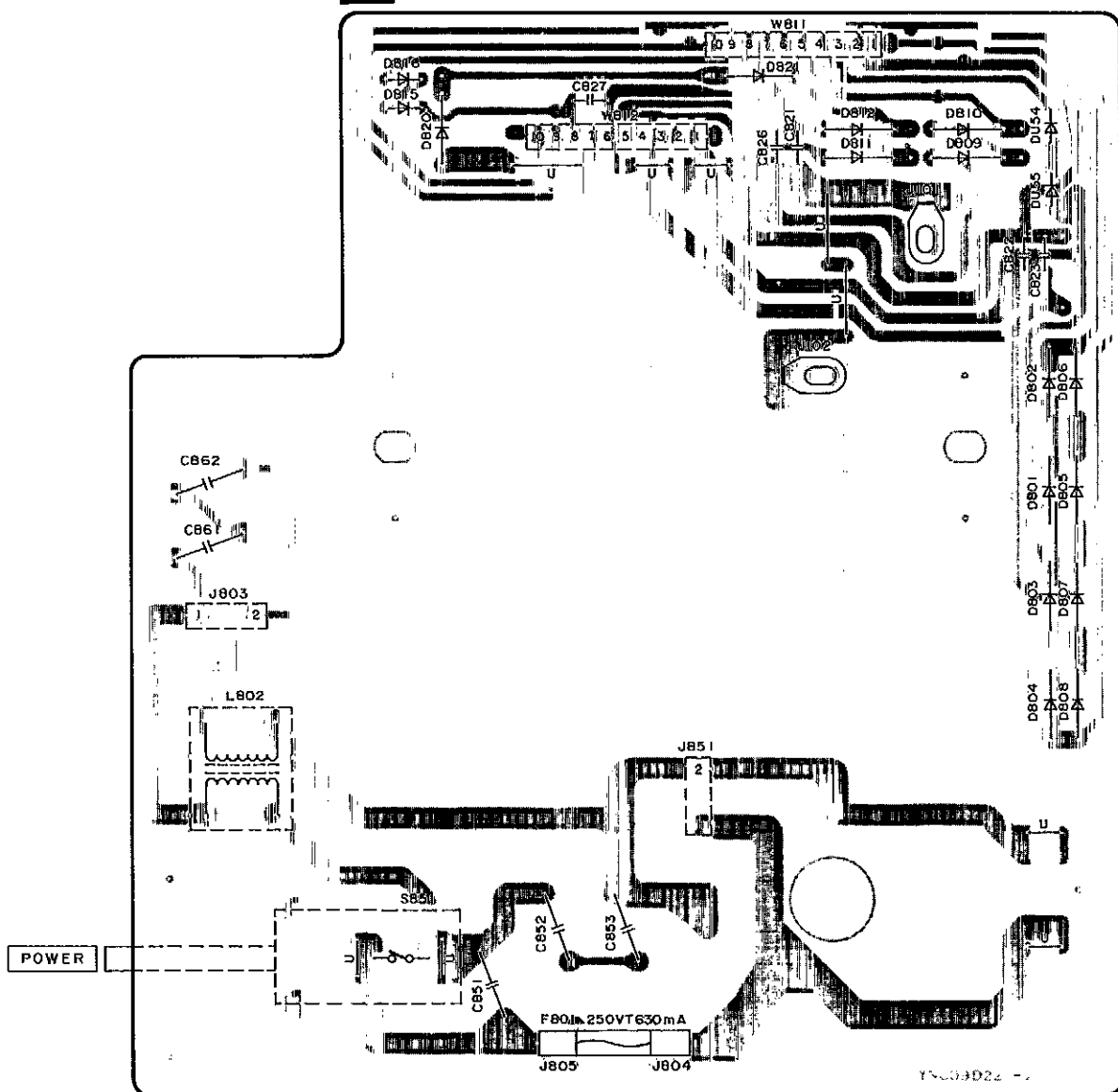

L REGULATOR P.C.B. (ZZ01D4120)

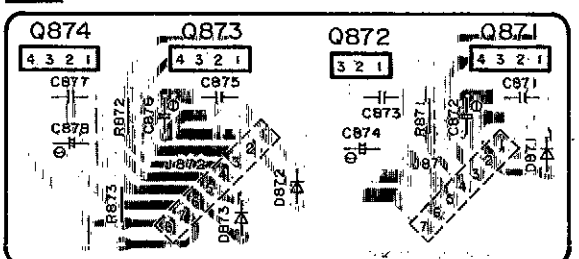

B CONNECTION P.C.B. (ZZ01D0410)

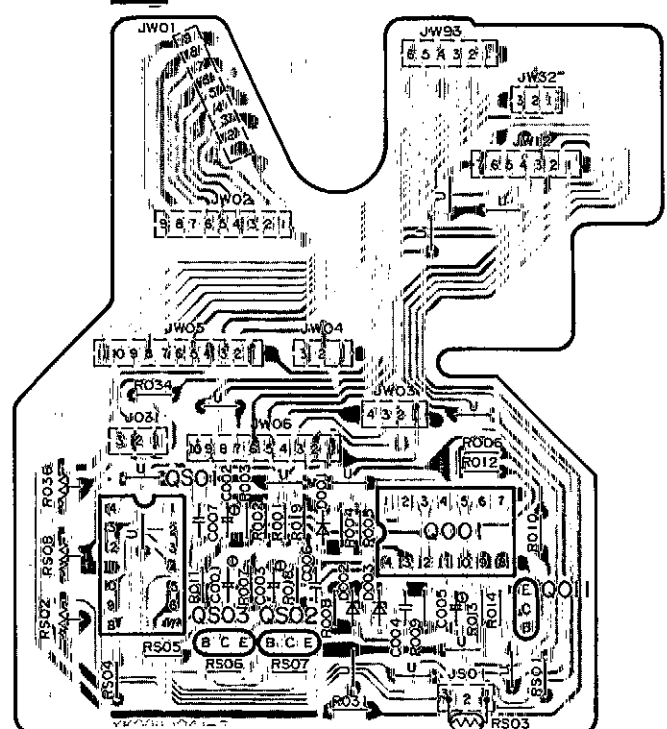

C MECHANISM P.C.B. (REP1406)

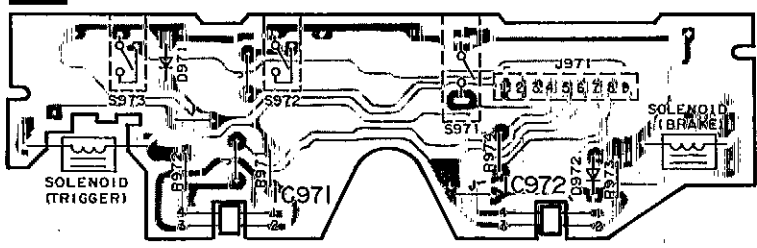

H MAIN P.C.B. (ZZ01D4110)

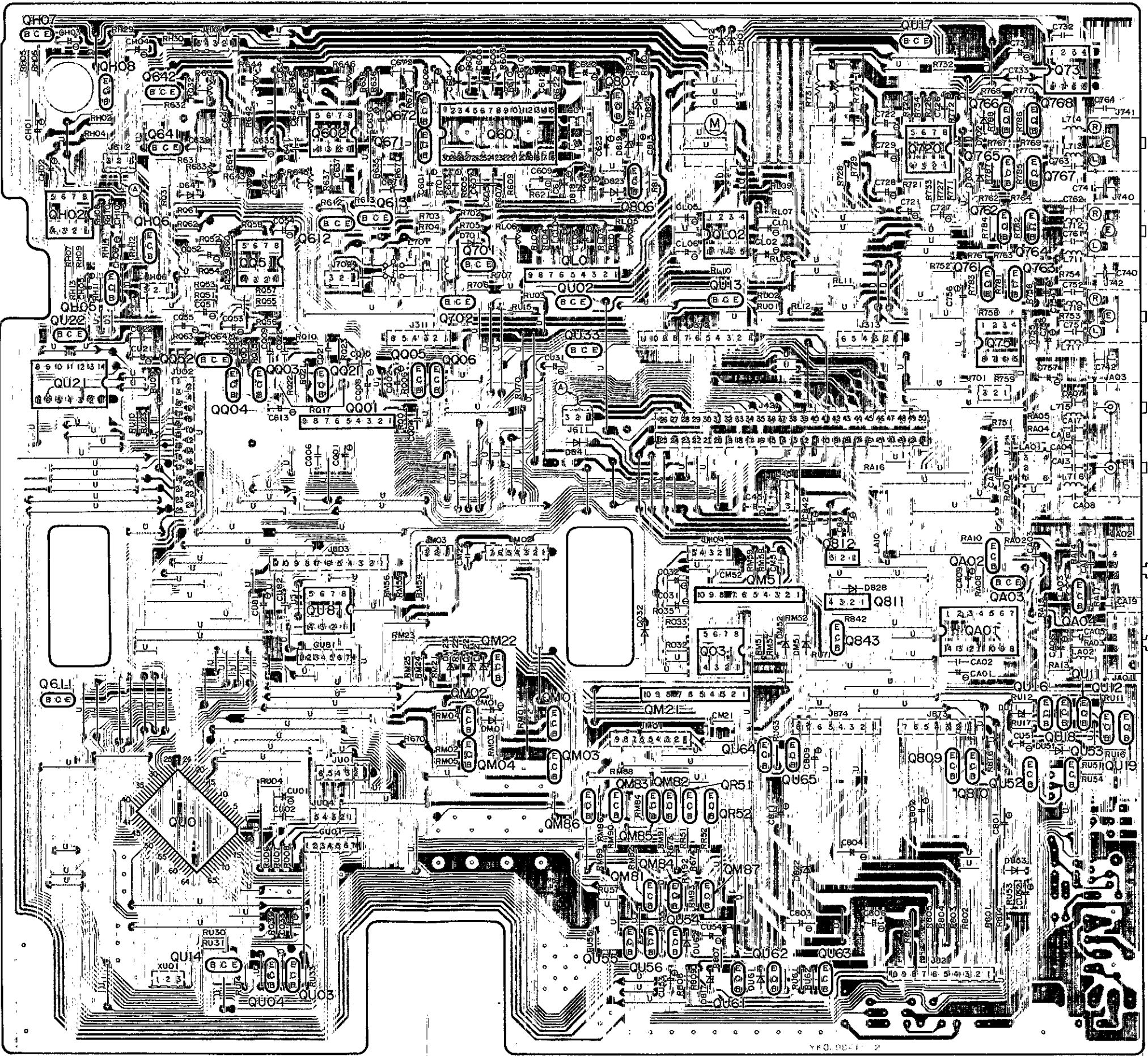

PLAY(OUT) VARIABLE
ANALOG
PLAY(OUT) FIX
REC (IN)
COAXIAL
PLAY (OUT)
DIGITAL
REC (IN)
OPTICAL
PLAY (OUT)

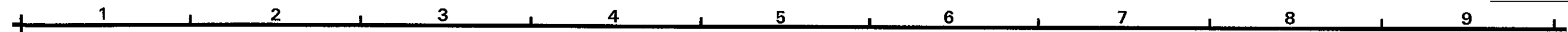

A
B
C
D
E
F
G

G AD/DA CONVERTER P.C.B. (ZZ01102010)

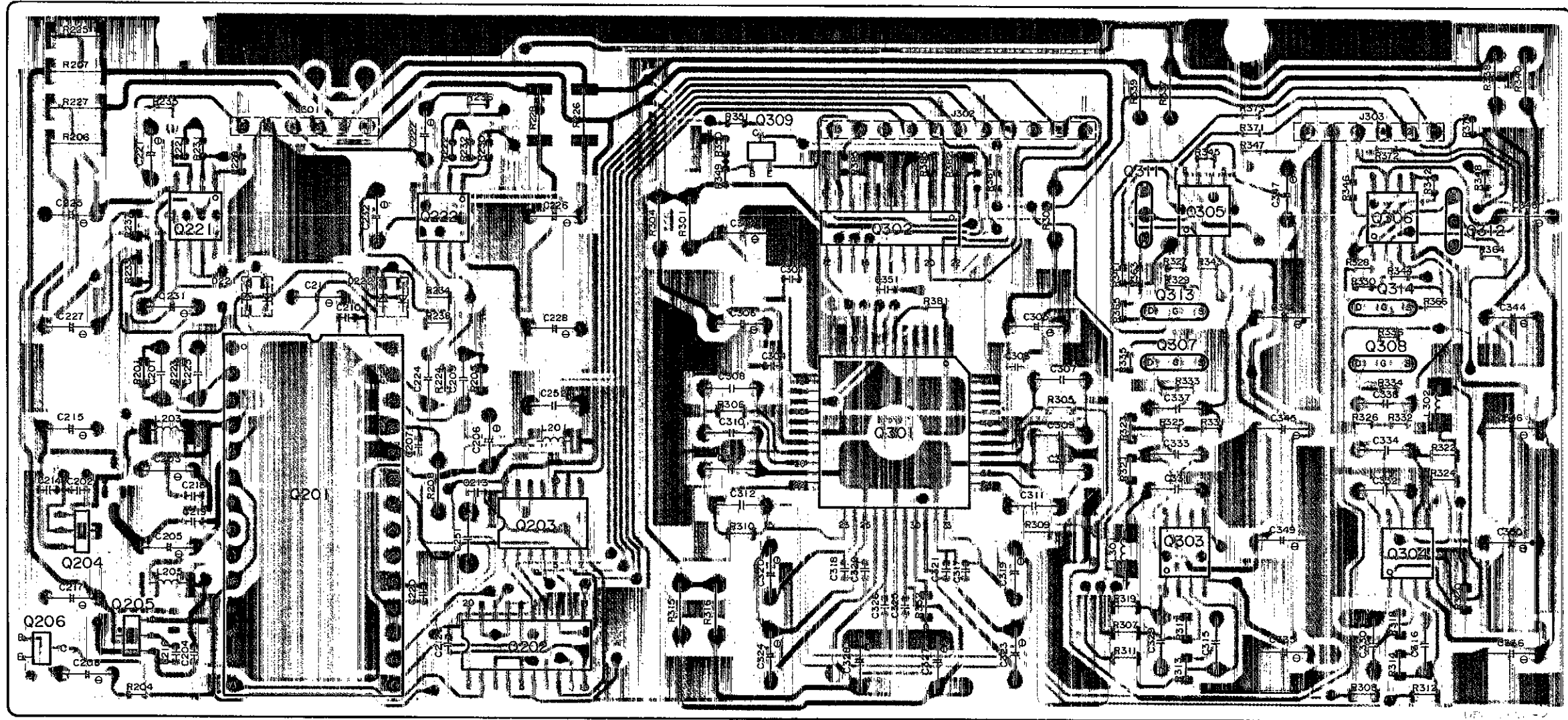

PACKAGING

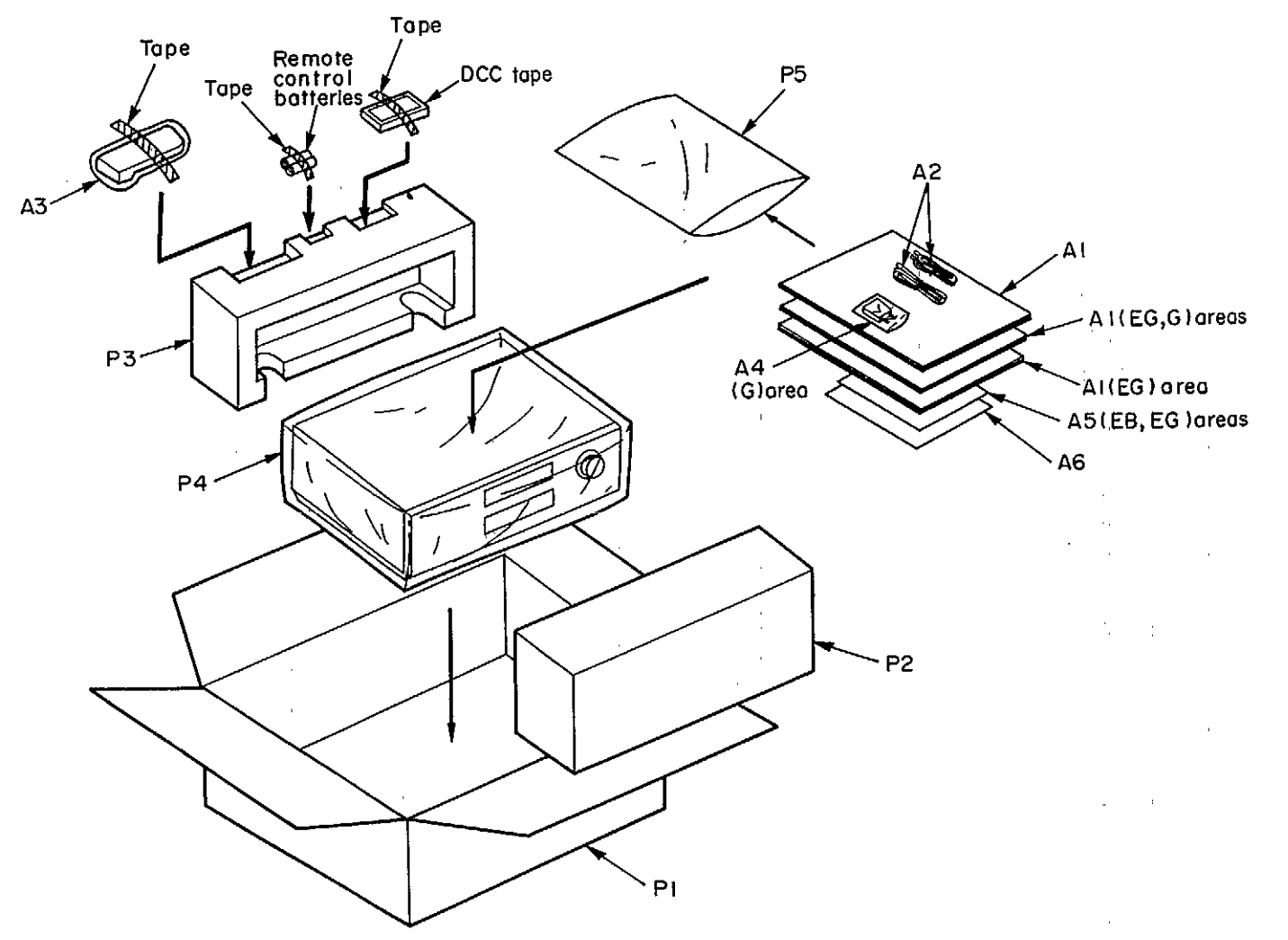

- Notes:**
- In this printed circuit board diagram (G), the parts and foil patterns on the board facing toward you are printed in black. The opposite side is printed in blue.
 - The “•” mark denotes the connection points of double-faced foil patterns (through holes) on both side of the printed circuit board.
 - This printed circuit board diagram may be modified at any time with the development of new technology.

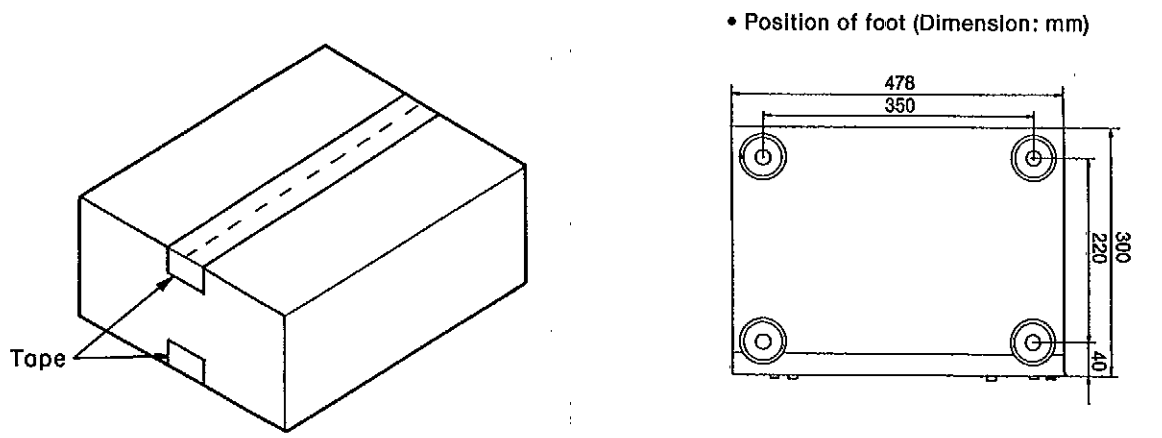

REPLACEMENT PARTS LIST

Notes: *Important safety notice:

 Components identified by Δ mark have special characteristics important for safety.

Furthermore, special parts which have purposes of fire-retardant (resistors), high-quality sound (capacitors), low-noise (resistors), etc. are used.

When replacing any of components, be sure to use only manufacturer's specified parts shown in the parts list.

*The parenthesized indications in the Remarks columns specify the areas. (Refer to the cover page for area.)

Parts without these indications can be used for all areas.

*Remote Control Ass'y:

Supply period for three years from termination of production.

Ref. No.	Part No.	Part Name & Description	Remarks	Ref. No.	Part No.	Part Name & Description	Remarks
		INTEGRATED CIRCUIT(S)		Q873	HC36905320	REGULATOR	Δ
				Q874	HC38905320	REGULATOR	Δ
IC971, 972	GP2S06BC	PHOTO COUPLER		QA01	HC700400U0	HEX UNBUFFERED INVERTER	
Q001	HC10010090	MOTOR CONTROL		QD01	HU10112060	PANEL CONTROL AND FL DRIVE	
Q031	HC10340050	QUICK SENSOR DRIVE		QD02	HW10012320	IR SENSOR	
Q101	HC10081490	READ AMP		QHO2	HC10089210	HEADPHONES AMP	
Q151	HC10082490	WRITE AMP		QL01	HC10050210	LEVEL METER CONTROL	
Q181	HC705300Z0	MULTIPLEXER		QL02	HC10089210	BUFFER AMP	
Q182	HC717500Z0	FLIP-FLOP		QM21	HC10093210	REEL MOTOR DRIVE	
Q183	HC700000Z0	NAND GATE		QM51	HC10279030	TRAY MOTOR DRIVE	
Q184	HC716300Z0	COUNTER		QQ01	HC10044210	QMS CONTROL	
Q185	HC700200Z0	NOR GATE		QQ51	HC10089210	-60dB LEVEL DETECTOR	
Q201	HC10002480	A/D CONVERTER		QS01	HC706600B0	QUAD ANALOG SWITCH	
Q202	HC737405Z0	FLIP-FLOP		QU01	HU10111060	MICROCOMPUTER	
Q203	HC700000Z0	NAND GATE		QU21	HC712500B0	QUAD 3-STATE BUFFER	
Q204	HC90005090	REGULATOR		QU81	HC10153210	EEP ROM	
Q205	HC99005090	REGULATOR				TRANSISTOR(S)	
Q221, 222	HC10033090	BUFFER AMP		Q011	HT30001000	TRANSISTOR	
Q301	HC10054490	D/A CONVERTER		Q102, 103	HX327121A0	TRANSISTOR	
Q302	HC10006350	DIGITAL FILTER		Q104	HX409992A0	TRANSISTOR	
Q303-306	HC10034090	FILTER AMP		Q105	HX111621A0	TRANSISTOR	
Q401	HC10075490	SBF-LEFT		Q106	HX327121A0	TRANSISTOR	
Q402	HC10075490	SBF-RIGHT		Q153	BA200030Z0	TRANSISTOR	
Q403	HC10076490	SBC		Q180	HX327121A0	TRANSISTOR	
Q404	HC10077490	DDSP2		Q190	HX327121A0	TRANSISTOR	
Q405	HC10078490	ERCO		Q206	BA10028210	TRANSISTOR	
Q406	HC10088180	DRAM(64Kx4)		Q307, 308	HF203722A0	F. E. T.	
Q409	HC453800Z0	LOGIC CONTROL		Q309	HX108122B0	TRANSISTOR	
Q410	HC10079490	ADAS		Q311-314	HF203722A0	F. E. T.	
Q412	HC703200Z0	OR GATE		Q411	BA200030Z0	TRANSISTOR	
Q423	HC10080490	DEQ2		Q421	HX327121A0	TRANSISTOR	
Q441	HC10142200	DATAL FILTER		Q422	HX111621A0	TRANSISTOR	
Q442	HC700400Z0	HEX INVERTER		Q611	BA10003210	TRANSISTOR	
Q443	HC10050270	PLL CONTROL		Q612	BA20010210	TRANSISTOR	
Q444	HC704649Z0	PLL		Q613	BA10007210	TRANSISTOR	
Q601	HC10023250	DOLBY NR B/C		Q641, 642	BA20028210	TRANSISTOR	
Q602	HC10053090	EQUALIZER AMP		Q671, 672	BA20010210	TRANSISTOR	
Q720	HC10089210	OUTPUT AMP		Q701	HT421592B0	TRANSISTOR	
Q731	HC10235030	MOTOR DRIVE		Q702	BA20017210	TRANSISTOR	
Q751	HC10053090	BUFFER AMP		Q761-768	HT421442A0	TRANSISTOR	
Q811	HC36905320	REGULATOR	Δ	Q806	HT421592B0	TRANSISTOR	
Q812	HC3850809F	REGULATOR	Δ	Q807	HT214252B0	TRANSISTOR	
Q871	HC36912320	REGULATOR	Δ	Q809, 810	BA20017210	TRANSISTOR	
Q872	HC3991209F	REGULATOR	Δ				

Ref. No.	Part No.	Part Name & Description	Remarks	Ref. No.	Part No.	Part Name & Description	Remarks
Q843	BA20017210	TRANSISTOR		D801-812	SVD1SR35200	DIODE	△
QA02	BA20010210	TRANSISTOR		D815, 816	SVD1SR35200	DIODE	△
QA03	HT10001000	TRANSISTOR		D817	MA4051M	ZENER	
QA04	HT30001000	TRANSISTOR		D818, 819	HD30821000	ZENER	
QD03	BA10007210	TRANSISTOR		D820, 821	SVD1SR35200	DIODE	△
QH05, 06	BA20028210	TRANSISTOR		D822	SVD1SR35200	DIODE	△
QH07, 08	BA20028210	TRANSISTOR		D823, 824	HD20002000	DIODE	
QM01	BA20017210	TRANSISTOR		D828	SVD1SR35200	DIODE	△
QM02	BA10003210	TRANSISTOR		D841	SVD1SR35200	DIODE	△
QM03	HT42010000	TRANSISTOR		D871-873	SVD1SR35200	DIODE	△
QM04	BA20017210	TRANSISTOR		D971, 972	RVD1SS133TA	DIODE	
QM22	BA20017210	TRANSISTOR		DD01	HI10114320	L. E. D. (GREEN)	
QM81-84	BA20017210	TRANSISTOR		DD02	HI10062320	L. E. D. (ORANGE)	
QM85, 86	HT320602B0	TRANSISTOR		DD04-06	HD20002000	DIODE	
QM87	HT214252B0	TRANSISTOR		DH01-04	HD20002000	DIODE	
QQ03-06	BA20017210	TRANSISTOR		DM01	HD20002000	DIODE	
QQ21	HT30001000	TRANSISTOR		DM21	MA4033M	ZENER	
QQ52	BA20017210	TRANSISTOR		DM22	HD30821000	ZENER	
QR51, 52	BA20012210	TRANSISTOR		DM23	HD20002000	DIODE	
QS02	BA20016210	TRANSISTOR		DM51	HD30821000	ZENER	
QS03	BA20012210	TRANSISTOR		DM52	HD20002000	DIODE	
QU02	BA20017210	TRANSISTOR		DU11	MA4039M	ZENER	
QU03-05	BA10007210	TRANSISTOR		DU51	HD20002000	DIODE	
QU11	BA10007210	TRANSISTOR		DU53	HD20002000	DIODE	
QU12	BA10003210	TRANSISTOR		DU54, 55	SVD1SR35200	DIODE	△
QU13, 14	BA20017210	TRANSISTOR		DU56	HD20002000	DIODE	
QU16	BA10003210	TRANSISTOR		DU61	HD20002000	DIODE	
QU17	BA20017210	TRANSISTOR		DU62	HD20029050	DIODE	
QU18	BA10007210	TRANSISTOR					
QU19	HT30001000	TRANSISTOR				VARIABLE RESISTOR(S)	
QU22	BA20010210	TRANSISTOR					
QU33	BA10010210	TRANSISTOR		R036	RA02230760	QUICK SENSOR ADJ.	
QU41	HT30001000	TRANSISTOR		R101, 102	NY04720090	ANALOG OUTPUT LEVEL ADJ.	
QU52	BA10007210	TRANSISTOR		R109, 110	NY04720090	ANALOG OUTPUT DIST. ADJ.	
QU53	BA20010210	TRANSISTOR		R135	NY01020090	DCC P. B. LEVEL ADJ.	
QU54	BA10010210	TRANSISTOR		R167	NY01010160	DCC OPT. REC. BIAS CURR. ADJ.	
QU55-57	BA20017210	TRANSISTOR		R455	NY01030090	PLL ADJ.	
QU61	BA20010210	TRANSISTOR		R633, 634	RA01030780	DOLBY NR ADJ.	
QU62	BA10007210	TRANSISTOR		R643, 644	RA04730780	ANALOG P. B. RES. ADJ. (HIGH)	
QU63	HT42010000	TRANSISTOR		R645, 646	RA04740780	ANALOG P. B. RES. ADJ. (LO)	
QU64	BA20010210	TRANSISTOR		R731	RY02030040	MOTOR VOLUME	
QU65	BA10007210	TRANSISTOR		RH01	RM02030430	PHONES LEVEL	
				RL05, 06	RA02220780	LEVEL METER ADJ.	
		DIODE(S)		RS02	RA04720760	TAPE SPEED ADJ. (FORWARD)	
				RS08	RA04710760	TAPE SPEED ADJ. (REVERSE)	
D001	HD20002000	DIODE		RV01	RM05031830	REC LEVEL	
D002, 003	HD70200490	ZENER		RV02	RM01041490	BALANCE	
D032	HD20002000	DIODE					
D221, 222	HZ20006020	DIODE				THERMISTOR(S)	
D421	HZ30018050	DIODE					
D701	SVD1SR35200	DIODE		R187	HH00030020	THERMISTOR	
D702, 703	HD20002000	DIODE		RS03	HH00031020	THERMISTOR	

Ref. No.	Part No.	Part Name & Description	Remarks	Ref. No.	Part No.	Part Name & Description	Remarks
		COIL (S)		S902	RSP1B001-A	TAPE DETECTION	(S902-1, 902-2)
				S971	RSHIA892C-U	MODE	
				S972	RSHIA90YC-U	CASSETTE HALF DETECTION	
L101, 102	LU01153010	COIL		S973	RSHIA90YC-U	ATS	
L201	LU12103010	COIL		SD01	SP0101128X	REPEAT	
L203	LU12103010	COIL		SD02	SP0101128X	SIDE A/B	
L205	LU12103010	COIL		SD03	SP0101128X	REW	
L301, 302	LU02224010	COIL		SD04	SP0101128X	FF	
L421	LU12104010	COIL		SD05	SP0101128X	SKIP (REVERSE)	
L441	LU12104010	COIL		SD06	SP0101128X	SKIP (FORWARD)	
L451	FM12223010	COIL		SD07	SP0101128X	PLAY	
L711-718	FC90050090	COIL		SD08	SP0101128X	STOP	
LA01	TP41042010	COIL		SD09	SP0101128X	APPEND	
LA02	LC11030140	CHOKE COIL		SD10	SP0101128X	RENUMBER	
LA03	LC14730140	CHOKE COIL		SD11	SP0101128X	MRK ERASE	
LH31-33	FC90050090	COIL		SD12	SP0101128X	NEXT MRK WRITE	
		TRANSFORMER (S)		SD13	SP0101128X	REVERSE MRK WRITE	
				SD14	SP0101128X	START MRK WRITE	
L801	TS16670030	POWER TRANSFORMER	(G) △	SD15	SP0101128X	PAUSE	
L801	TS16670010	POWER TRANSFORMER	(EB, EG) △	SD16	SP0101128X	REC	
L802	FN01010020	TRANSFORMER	△	SD17	SP0101128X	TRAY OPEN/CLOSE	
		COMPONENT COMBINATION (S)		SD19	SP0101128X	COUNTER RESET	
				SD20	SP0101128X	TEXT	
GD01	BW05473120	COMBINATION PART (47kX10)		SD21	SP0101128X	COUNTER	
GD02	BW05473110	COMBINATION PART (47kX9)		SD23	SP0101128X	AUTO START MRK	
GD03	BW05473100	COMBINATION PART (47kX8)		SD24	SP0101128X	AUTO REC MUTE	
GD04	BW05473090	COMBINATION PART (47kX7)		SD31	SR01030080	TIMER	
GU01	BW05103150	COMBINATION PART (10kX6)		SD32	SR01030070	DOLBY NR	
GU81	BW05103150	COMBINATION PART (10kX6)		SD33	SR01030070	INPUT SELECTOR	
		OSCILLATOR(S)				RELAY (S)	
				L701	LY20120320	RELAY	
X401	FZ02455010	CERAMIC FILTER (24MHz)				CONNECTOR (S) AND SOCKET (S)	
X402	FZ02255010	CERAMIC FILTER (22MHz)					
XD01	FQ04194020	CERAMIC FILTER (4.19MHz)		J031	YP06006930	CONNECTOR (3P)	
XU01	FQ04194020	CERAMIC FILTER (4.19MHz)		J101	YJ07006250	CONNECTOR (30P)	
		DISPLAY TUBE (S)		J103	YJ07006090	CONNECTOR (18P)	
				J301	YP06006290	CONNECTOR (6P)	
VD01	HQ31605060	FL DISPLAY TUBE	△	J302	YP06006470	CONNECTOR (11P)	
		FUSE (S)		J303	YP06006290	CONNECTOR (6P)	
				J311	YJ06008760	SOCKET (6P)	
F801	FS10063850	FUSE, 250V, T630mA	△	J312	YJ06008810	SOCKET (11P)	
		SWITCH (ES)		J313	YJ06008760	SOCKET (6P)	
				J408	YJ07006100	CONNECTOR (18P)	
J091	BY05080070	VOLTAGE SELECTOR	(G) △	J421	YJ07006130	CONNECTOR (50P)	
S851	SP01011830	POWER	△	J601	YP06006930	CONNECTOR (6P)	
S901	RSP1C001-A	TAPE P. TIME DETECTION	(S901-1-901-3)	J701, 702	YP06003830	CONNECTOR (3P)	
				J803	YP04000760	CONNECTOR (2P)	
				J813	YP06011900	CONNECTOR (10P)	
				J821	YP06012300	CONNECTOR (10P)	

Ref. No.	Part No.	Part Name & Description	Remarks	Ref. No.	Part No.	Part Name & Description	Remarks
J851	YP04000760	CONNECTOR (2P)		WM02	YB00203600	CONNECTIVE CORD (9P)	
J871	YP06010460	CONNECTOR (7P)		WM05	YB00203620	CONNECTIVE CORD (11P)	
J872	YP06003880	CONNECTOR (8P)		WM06	YB00203610	CONNECTIVE CORD (10P)	
J873	YP06010460	CONNECTOR (7P)		WM12	YB00181790	CONNECTIVE CORD (7P)	
J874	YP06003880	CONNECTOR (8P)		WM93	YB00240940	CONNECTIVE CORD (6P)	
JD01	YJ07006080	CONNECTOR (25P)		WV01	YB00203280	CONNECTIVE CORD (3P)	
JH04	YP06006650	CONNECTOR (5P)		WV02	YB00340510	CONNECTIVE CORD (4P)	
JH06	YP06003830	CONNECTOR (3P)				GND PART(S)	
JM01	YP06006690	CONNECTOR (9P)		JJ01	YL01010110	EARTH GROUND	
JM02	YP06006670	CONNECTOR (7P)		JJ02	309V129010	EARTH GROUND	
JM03	YP06003830	CONNECTOR (3P)				HOLDER(S)	
JM04	YP06006650	CONNECTOR (5P)		J804	YJ08000430	FUSE HOLDER	
JU01	YP06006660	CONNECTOR (6P)		J805	YJ08000450	FUSE HOLDER	
JU02	YJ07006070	CONNECTOR (25P)					
JU04	YP06006650	CONNECTOR (5P)					
JV01	YP06003830	CONNECTOR (3P)					
JV02	YP06003910	CONNECTOR (4P)					
JW01	YJ06011690	CONNECTOR (9P)					
JW02	YP06006690	CONNECTOR (9P)					
JW03	YP06006640	CONNECTOR (4P)					
JW04	YP06003830	CONNECTOR (3P)					
JW05	YP06006710	CONNECTOR (11P)					
JW06	YP06006700	CONNECTOR (10P)					
JW12	YP06006670	CONNECTOR (7P)					
JW32	YJ06006230	CONNECTOR (3P)					
JW93	YJ06006260	CONNECTOR (6P)					
		JACK (S)					
J740	YT02021080	TERMINAL BOARD (2P) : FIX					
J741	YT02021080	TERMINAL BOARD (2P) : VARIABLE					
J742	YT02021080	TERMINAL BOARD (2P) : REC					
JA01	YJ15000080	OPTICAL PLAY					
JA02	YJ15000120	OPTICAL REC					
JA03	YT02021070	TERMINAL BOARD (2P) : COAXIAL					
JH02	YJ01003490	JACK, HEADPHONES					
		FLAT CABLE (S)					
J611 (J612)	YB00170640	CONNECTIVE CORD (3P)					
WD10	YW009D0010	WIRE MATERIALS	(G)				
W103	YU18200520	FPC BOARD (18P)					
W803	YB00181770	CONNECTIVE CORD (2P)	(EB, EG)				
W803	YB00203570	CONNECTIVE CORD (2P)	(G)				
W811	YB00050850	CONNECTIVE CORD (10P)					
W812	YB00081430	CONNECTIVE CORD (10P)					
W871	YB00121600	CONNECTIVE CORD (7P)					
W872	YB00121610	CONNECTIVE CORD (8P)					
WD01	YU25150520	FPC BOARD (25P)					
WH01	YB00104160	CONNECTIVE CORD (5P)					
WH03	YB00081510	CONNECTIVE CORD (3P)					
WM01	YU09220270	FLAT CABLE (9P)					

RESISTORS AND CAPACITORS

Notes : * Capacity values are in microfarads (μF) unless specified otherwise, P=Pico-farads (pF) F=Farads (F)
 * Resistance values are in ohms, unless specified otherwise, 1K=1,000(OHM) , 1M=1,000k(OHM)

Ref. No.	Part No.	Values & Remarks	Ref. No.	Part No.	Values & Remarks	Ref. No.	Part No.	Values & Remarks
		RESISTORS	R184	NI05560110	1/10W 56	R371-374	NN05106610	1/16W 10M
			R185	NN05182610	1/16W 1.8K	R402	ERJ2GEYJ104V	1/16W 100K
			R186	NN05680610	1/16W 68	R411	ERJ2GEYJ222V	1/16W 2.2K
R001	ERDS2TJ472	1/4W 4.7K	R192	NN05182610	1/16W 1.8K	R423	ERJ2GEYJ272V	1/16W 2.7K
R002	ERDS2TJ683	1/4W 68K	R193	ERJ2GEYJ152V	1/16W 1.5K	R428	ERJ2GEYJ123V	1/16W 12K
R003	ERDS2TJ274	1/4W 270K	R194	NN05561610	1/16W 560	R429	ERDS2TJ121	1/4W 120
R004	ERDS2TJ102	1/4W 1K	R195	NN05121610	1/16W 120	R430	ERDS2TJ181	1/4W 180
R005, 006	ERDS2TJ104	1/4W 100K	R196-198	NN05390610	1/16W 39	R432	NN05221610	1/16W 220
R007	ERDS2TJ682	1/4W 6.8K	R201	NI01510110	1/10W 51	R434, 435	ERJ2GEYJ473V	1/16W 47K
R008	ERDS2TJ104	1/4W 100K	R204	ERJ2GEYJ473V	1/16W 47K	R441	ERJ2GEYJ103V	1/16W 10K
R009, 010	ERDS2TJ472	1/4W 4.7K	R205	NI01510110	1/10W 51	R442	ERJ2GEYJ104V	1/16W 100K
R011	ERDS2TJ103	1/4W 10K	R206, 207	RI05121120	1/2W 120	R443, 444	ERJ2GEYJ222V	1/16W 2.2K
R012	ERDS2TJ332	1/4W 3.3K	R208	ERQ12AJ4R7	1/2W 4.7 Δ	R445	ERJ2GEYJ122V	1/16W 1.2K
R013	ERDS2TJ392	1/4W 3.9K	R221, 222	ERJ2GEYJ104V	1/16W 100K	R447	ERJ2GEYJ104V	1/16W 100K
R014	ERDS2TJ184	1/4W 180K	R223, 224	NI01510110	1/10W 51	R448, 449	NN05223610	1/16W 22K
R018, 019	ERJ2GEYJ154V	1/4W 10K	R225-228	RI05121120	1/2W 120	R450	ERJ2GEYJ103V	1/16W 10K
R031	ERDS2TJ151	1/4W 150 Δ	R229, 230	NN05223610	1/16W 22K	R451, 452	NN05303610	1/16W 30K
R032	ERDS2TJ103	1/4W 10K	R231, 232	ERJ2GEYJ222V	1/16W 2.2K	R453	ERJ2GEYJ472V	1/16W 4.7K
R033	ERDS2TJ102	1/4W 1K	R233, 234	NI01102110	1/10W 1K	R454	ERJ2GEYJ682V	1/16W 6.8K
R034	ERDS2TJ222	1/4W 2.2K	R235, 236	NN05182610	1/16W 1.8K	R471	ERJ2GEYJ105V	1/16W 1M
R035	ERDS2TJ104	1/4W 100K	R237, 238	NI01473110	1/10W 47K	R472	ERJ2GEYJ102V	1/16W 1K
R039	ERDS2TJ104	1/4W 100K	R301	ERQ12AJ4R7	1/2W 4.7 Δ	R473	ERJ2GEYJ105V	1/16W 1M
R103, 104	ERJ2GEYJ473V	1/16W 47K	R303, 304	ERQ12AJ4R7	1/2W 4.7 Δ	R474	ERJ2GEYJ102V	1/16W 1K
R105, 106	NN05303610	1/16W 30K	R305, 306	NI01473110	1/10W 47K	R479-484	NN05330610	1/16W 33
R107, 108	ERJ2GEYJ154V	1/16W 150K	R307, 308	NI01822110	1/10W 8.2K	R485	ERJ2GEYJ102V	1/16W 1K
R111-114	NN05100610	1/16W 10	R309, 310	NI01473110	1/10W 47K	R487-490	NN05330610	1/16W 33
R115, 116	NN05561610	1/16W 560	R311-314	NI01822110	1/10W 8.2K	R491-498	ERJ2GEYJ472V	1/16W 4.7K
R121	ERJ2GEYJ682V	1/16W 6.8K	R315, 316	ERDS2TJ101	1/4W 100	R499	NN05330610	1/16W 33
R122	NN05683610	1/16W 68K	R317, 318	NI01822110	1/10W 8.2K	R605-608	ERDS2TJ123	1/4W 12K
R125	ERJ2GEYJ104V	1/16W 100K	R319, 320	NI01562110	1/10W 5.6K	R609, 610	ERDS2TJ561	1/4W 560
R127, 128	ERJ2GEYJ102V	1/16W 1K	R321, 322	NI01752110	1/10W 7.5K	R612, 613	ERDS2TJ682	1/4W 6.8K
R129	ERJ2GEYJ470V	1/16W 47	R323, 324	NI01562110	1/10W 5.6K	R621	ERDS2TJ102	1/4W 1K
R130	ERJ2GEYJ471V	1/16W 470	R325, 326	ERJ2GEYJ102V	1/16W 1K	R622	ERDS2TJ273	1/4W 27K
R131	ERJ2GEYJ331V	1/16W 330	R327, 328	ERJ2GEYJ272V	1/16W 2.7K	R631, 632	ERDS2TJ153	1/4W 15K
R132	NN05561610	1/16W 560	R329, 330	ERJ2GEYJ682V	1/16W 6.8K	R635, 636	ERDS2TJ102	1/4W 1K
R133	ERJ2GEYJ822V	1/16W 8.2K	R331, 332	ERJ2GEYJ101V	1/16W 100	R637, 638	ERDS2TJ103	1/4W 10K
R134	ERJ2GEYJ123V	1/16W 12K	R333, 334	ERJ2GEYJ471V	1/16W 470	R641, 642	ERDS2TJ102	1/4W 1K
R136	NN05393610	1/16W 39K	R335, 336	NN05106610	1/16W 10M	R647, 648	ERDS2TJ332	1/4W 3.3K
R137-145	ERJ6GEYJ561V	1/10W 560	R337-340	NF02100140	1/2W 10 Δ	R670	ERDS2TJ103	1/4W 10K
R146	NN05561610	1/16W 560	R341, 342	ERJ2GEYJ101V	1/16W 100	R671, 672	ERDS2TJ102	1/4W 1K
R151	ERDS2TJ120	1/4W 12	R343, 344	ERJ2GEYJ183V	1/16W 18K	R673	ERDS2TJ103	1/4W 10K
R155	ERDS2TJ2R2	1/4W 2.2	R345, 346	ERJ2GEYJ101V	1/16W 100	R674	ERDS2TJ472	1/4W 4.7K
R156	ERDS2TJ181	1/4W 180	R347, 348	NN05223610	1/16W 22K	R701, 702	ERDS2TJ123	1/4W 12K
R158-166	NN05220610	1/16W 22	R349	ERJ2GEYJ473V	1/16W 47K	R703, 704	ERDS2TJ152	1/4W 1.5K
R171, 172	ERJ2GEYJ472V	1/16W 4.7K	R350	ERJ2GEYJ153V	1/16W 15K	R705	NF02100140	1/2W 10 Δ
R180	ERJ2GEYJ102V	1/16W 1K	R351	ERJ2GEYJ104V	1/16W 100K	R706, 707	ERDS2TJ222	1/4W 2.2K
R181	ERJ2GEYJ331V	1/16W 330	R352	NI01243110	1/10W 24K	R720, 721	ERDS2TJ473	1/4W 47K
R182	NN05100610	1/16W 10	R363, 364	ERJ2GEYJ332V	1/16W 3.3K	R728, 729	NF02100140	1/2W 10 Δ
R183	ERJ2GEYJ822V	1/16W 8.2K	R365, 366	ERJ2GEYJ472V	1/16W 4.7K	R732	ERQ12AJ4R7	1/2W 4.7 Δ

Ref. No.	Part No.	Values & Remarks	Ref. No.	Part No.	Values & Remarks	Ref. No.	Part No.	Values & Remarks
R733, 734	ERDS2TJ101	1/4W 100	RD26	ERDS2TJ151	1/4W 150	RQ59, 60	ERDS2TJ102	1/4W 1K
R751, 752	NF02100140	1/2W 10 Δ	RD31-38	ERDS2TJ103	1/4W 10K	RQ61, 62	NF02100140	1/2W 10 Δ
R753, 754	ERDS2TJ473	1/4W 47K	RH02	NF02100140	1/2W 10 Δ	RQ63	ERDS2TJ103	1/4W 10K
R755, 756	ERDS2TJ102	1/4W 1K	RH04	NF02100140	1/2W 10 Δ	RQ64	ERDS2TJ473	1/4W 47K
R758, 759	ERDS2TJ101	1/4W 100	RH05, 06	ERDS2TJ473	1/4W 47K	RR51, 52	ERDS2TJ103	1/4W 10K
R761-764	ERDS2TJ221	1/4W 220	RH07, 08	ERDS2TJ103	1/4W 10K	RS01	ERDS2TJ123	1/4W 12K
R767-770	ERDS2TJ221	1/4W 220	RH09, 10	ERDS2TJ223	1/4W 22K	RS04	ERDS2TJ221	1/4W 220
R771, 772	ERDS2TJ104	1/4W 100K	RH11, 12	ERDS2TJ121	1/4W 120	RS06, 07	ERDS2TJ472	1/4W 4.7K
R781-788	ERDS2TJ222	1/4W 2.2K	RH13, 14	ERDS2TJ103	1/4W 10K	RU01-10	ERDS2TJ103	1/4W 10K
R801	RF05010120	1/2W 1 Δ	RH29, 30	ERDS2TJ103	1/4W 10K	RU11	ERDS2TJ101	1/4W 100
R802	RF05022120	1/2W 2.2 Δ	RL01, 02	ERDS2TJ103	1/4W 10K	RU12	ERDS2TJ222	1/4W 2.2K
R803-805	RF05010120	1/2W 1 Δ	RL03, 04	ERDS2TJ104	1/4W 100K	RU14	ERDS2TJ103	1/4W 10K
R806	NH05010140	1/4W 1 Δ	RL07, 08	ERDS2TJ473	1/4W 47K	RU15	ERDS2TJ102	1/4W 1K
R807	ERDS2TJ472	1/4W 4.7K	RL09, 10	NF02100140	1/2W 10 Δ	RU16	ERDS2TJ104	1/4W 100K
R808, 809	ERDS2TJ151	1/4W 150	RL11, 12	ERDS2TJ101	1/4W 100	RU17	ERDS2TJ103	1/4W 10K
R810	NF02100140	1/2W 10 Δ	RM01	ERG1ANJ2R2	1W 2.2 Δ	RU21	ERDS2TJ472	1/4W 4.7K
R811, 812	ERDS2TJ222	1/4W 2.2	RM02	ERDS2TJ222	1/4W 2.2K	RU23	ERDS2TJ103	1/4W 10K
R813, 814	NF02100140	1/2W 10 Δ	RM03	ERDS2TJ223	1/4W 22K	RU30	ERDS2TJ103	1/4W 10K
R816	ERDS2TJ103	1/4W 10K	RM04	ERDS2TJ473	1/4W 47K	RU31	ERDS2TJ472	1/4W 4.7K
R820	ERDS2TJ104	1/4W 100K	RM05	ERDS2TJ103	1/4W 10K	RU33	ERDS2TJ103	1/4W 10K
R842	ERDS2TJ104	1/4W 100K	RM21	ERDS2TJ561	1/4W 560	RU51	ERDS2TJ470	1/4W 47
R871, 872	ERDS2TJ104	1/4W 100K	RM22	ERDS2TJ222	1/4W 2.2K	RU53	ERDS2TJ222	1/4W 2.2K
R873	ERDS2TJ103	1/4W 10K	RM23	NH05047140	1/4W 4.7 Δ	RU54	ERDS2TJ103	1/4W 10K
R971	ERDS2TJ221	1/4W 220	RM24, 25	ERDS2TJ222	1/4W 2.2K	RU55	ERDS2TJ102	1/4W 1K
R972	ERDS2TJ183T	1/4W 18K	RM51	ERDS2TJ561	1/4W 560	RU56	ERDS2TJ473	1/4W 47K
R973	ERDS2TJ221	1/4W 220	RM52	ERDS2TJ222	1/4W 2.2K	RU57	ERDS2TJ102	1/4W 1K
R974	ERDS2TJ183T	1/4W 18K	RM54	ERDS2TJ222	1/4W 2.2K	RU61, 62	ERDS2TJ472	1/4W 4.7K
RA01	ERDS2TJ391	1/4W 390	RM55	ERDS2TJ102	1/4W 1K	RU63	ERDS2TJ102	1/4W 1K
RA02	ERDS2TJ681	1/4W 680	RM56	ERDS2TJ103	1/4W 10K	RU71	ERDS2TJ103	1/4W 10K
RA03	ERDS2TJ822	1/4W 8.2K	RM57	NH05047140	1/4W 4.7 Δ	RV03, 04	ERDS2TJ102	1/4W 1K
RA04, 05	ERDS2TJ151	1/4W 150	RM58, 59	ERDS2TJ222	1/4W 2.2K			CHIP JUMPERS
RA08	ERDS2TJ104	1/4W 100K	RM82	ERDS2TJ222	1/4W 2.2K			
RA10	ERDS2TJ221	1/4W 220	RM84	ERDS2TJ222	1/4W 2.2K			
RA13	ERDS2TJ390	1/4W 39	RM86	ERDS2TJ222	1/4W 2.2K	CA10	75060501P0	CHIP JUMPER
RA15	ERDS2TJ390	1/4W 39	RM88	ERG1ANJ330	1W 33	J111, 112	ERJ6GEYJ000V	CHIP JUMPER
RD01	ERDS2TJ472	1/4W 4.7K	RM89-91	ERDS2TJ103	1/4W 10K	J121, 122	ERJ6GEYJ000V	CHIP JUMPER
RD02	ERDS2TJ222	1/4W 2.2K	RM92	ERDS2TJ102	1/4W 1K	J151, 152	ERJ6GEYJ000V	CHIP JUMPER
RD03	ERDS2TJ102	1/4W 1K	RM93	ERDS2TJ473	1/4W 47K	J409	ERJ6GEYJ000V	CHIP JUMPER
RD04	ERDS2TJ103	1/4W 10K	RQ01	ERDS2TJ104	1/4W 100K	J441, 442	ERJ6GEYJ000V	CHIP JUMPER
RD05	ERDS2TJ472	1/4W 4.7K	RQ03	ERDS2TJ682	1/4W 6.8K	LA10	75060501P0	CHIP JUMPER
RD06	ERDS2TJ222	1/4W 2.2K	RQ06, 07	ERDS2TJ103	1/4W 10K	R199	RI05000180	CHIP JUMPER
RD07	ERDS2TJ102	1/4W 1K	RQ10	ERDS2TJ103	1/4W 10K	R381-383	NN05000610	CHIP JUMPER
RD08	ERDS2TJ103	1/4W 10K	RQ15	ERDS2TJ104	1/4W 100K	R385	NN05000610	CHIP JUMPER
RD09	ERDS2TJ682	1/4W 6.8K	RQ17	ERG1ANJ151	1W 150 Δ	R387	NN05000610	CHIP JUMPER
RD10	ERDS2TJ472	1/4W 4.7K	RQ21	ERDS2TJ822	1/4W 8.2K	R413	NN05000610	CHIP JUMPER
RD11	ERDS2TJ222	1/4W 2.2K	RQ22	ERDS2TJ331	1/4W 330	R417	NN05000610	CHIP JUMPER
RD12	ERDS2TJ102	1/4W 1K	RQ23	ERDS2TJ105	1/4W 1M	R422	RI05000180	CHIP JUMPER
RD13	ERDS2TJ103	1/4W 10K	RQ31, 32	ERDS2TJ104	1/4W 100K	RA06	75060501P0	CHIP JUMPER
RD17	ERDS2TJ822	1/4W 8.2K	RQ51, 52	ERDS2TJ104	1/4W 100K	RH15	75060501P0	CHIP JUMPER
RD18	ERDS2TJ103	1/4W 10K	RQ53, 54	ERDS2TJ223	1/4W 22K	RJ03, 04	NN05000610	CHIP JUMPER
RD19	ERDS2TJ680	1/4W 68	RQ55, 56	ERDS2TJ103	1/4W 10K			
RD20	ERDS2TJ681	1/4W 680	RQ57, 58	ERDS2TJ472	1/4W 4.7K			CAPACITORS

Ref. No.	Part No.	Values & Remarks	Ref. No.	Part No.	Values & Remarks	Ref. No.	Part No.	Values & Remarks
			C221, 222	ECA1EPXS470B	25V 47U	C451	0A47701620	16V 470U
C001	0A22405020	50V 0. 22U	C223, 224	DF15103350	50V 0. 01U	C457	ECCF1H151JC	50V 150P
C002	EQ22505030	50V 2. 2U	C225-228	ECA1CPXS221B	16V 220U	C471-474	ECCF1H07DCC	50V 7P
C003	EQ47405030	50V 0. 47U	C231, 232	ECA1EPXS470B	25V 47U	C601-604	ECA1HPXS4R7B	50V 4. 7U
C004	ECKF1H103ZF	50V 0. 01U	C251, 252	ECKF1H103ZF	50V 0. 01U	C605-608	DF16222310	50V 2200P
C005	ECA0JPXS221B	6. 3V 220U	C301	ECKF1E104ZV	25V 0. 1U	C609, 610	EA56405010	50V 0. 58U
C006, 007	DD38104010	25V 0. 1U	C302	0A47601050	10V 47U	C611, 612	EA33405010	50V 0. 33U
C031	ECA1HPXS4R7B	50V 4. 7U	C303, 304	ECKF1E104ZV	25V 0. 1U	C613	ECA1EPXS100B	25V 10U
C032	ECA1CPXS100B	16V 10U	C305, 306	0A47601050	10V 47U	C622, 623	ECA1CPXS101B	16V 100U
C033	ECA1HPXS2R2B	50V 2. 2U	C307, 308	ECCF1H390JC	50V 39P	C633, 634	DF16472310	50V 4700P
C101	ECKF1E104ZV	25V 0. 1U	C309, 310	ECQP1H471JZ	50V 470P	C635, 636	ECA1CPXS221B	16V 220U
C102	ECST1CY105	16V 1U	C311, 312	ECCF1H390JC	50V 39P	C637, 638	ECQP1H223JZ	50V 0. 022U
C103	EY47501640	16V 4. 7U	C313, 314	ECQP1H471JZ	50V 470P	C639, 640	DA16221110	50V 220P
C104-111	DK58105200	16V 1U	C315, 316	DF15101550	100V 100P	C641, 642	ECQP1H152JZ3	50V 1500P
C112	EY10601620	16V 10U	C317, 318	ECKF1E104ZV	25V 0. 1U	C671, 672	ECQP1H223JZ	50V 0. 022U
C113, 114	ECST1CY105	16V 1U	C319, 320	0A47601050	10V 47U	C721, 722	ECA1HPXS4R7B	50V 4. 7U
C115, 116	EY22500610	6. 3V 2. 2U	C321, 322	ECKF1E104ZV	25V 0. 1U	C726, 727	ECA1CPXS470B	16V 47U
C117, 118	DK96182300	50V 1800P	C323, 324	0A47601050	10V 47U	C728, 729	ECA1CPXS221B	16V 220U
C119-121	EY10601620	16V 10U	C325, 326	ECKF1E104ZV	25V 0. 1U	C731	ECA1CPXS101B	16V 100U
C122-132	ECUX1H103KB	50V 0. 01U	C327, 328	0A47601050	10V 47U	C732, 733	DA17473110	50V 0. 047U
C133, 134	ECKF1E104ZV	25V 0. 1U	C329, 330	DF15101550	100V 100P	C740-742	DD38104010	25V 0. 1U
C135	EY68601020	10V 63U	C331, 332	DF15102350	50V 1000P	C751, 752	ECBA1H101KB5	50V 100P
C137	EY68601020	10V 63U	C333, 334	DF15101550	100V 100P	C753, 754	ECA1HPXS4R7B	50V 4. 7U
C138	ECKF1E104ZV	25V 0. 1U	C335, 336	ECA1CPXS221B	16V 220U	C756, 757	ECA1CPXS221B	16V 220U
C140	EY68601020	10V 63U	C337, 338	ECQMLH333JZ	50V 0. 033U	C761-764	ECBA1H221KBY	50V 220P
C141	ECKF1E104ZV	25V 0. 1U	C343-346	ECA1CPXS221B	16V 220U	C801	EA47803510	35V 4700U
C143	EY47501640	16V 4. 7U	C347, 348	ECA1EPXS101B	25V 100U	C802	ECA1VM222B	35V 2200U
C144, 145	DK58105200	16V 1U	C349, 350	ECA1CPXS221B	16V 220U	C803, 804	ECA1EM472	25V 4700U
C150	EY68601020	10V 63U	C351	ECKF1E104ZV	25V 0. 1U	C806	ECA1HM471B	50V 470U
C151, 152	ECKF1E104ZV	25V 0. 1U	C401-406	ECKF1E104ZV	25V 0. 1U	C809	ECA1HPXS100B	50V 10U
C157-165	DK96332300	50V 3300P	C409, 410	ECKF1E104ZV	25V 0. 1U	C810	DA17473110	50V 0. 047U
C181-185	ECKF1E104ZV	25V 0. 1U	C411	ECUX1H103KB	50V 0. 01U	C811	ECA1EM472	25V 4700U
C190, 191	ECUX1H333ZF	50V 0. 033U	C412	ECKF1E104ZV	25V 0. 1U	C812, 813	ECA1CPXS100B	16V 10U
C192	DK96102300	50V 1000P	C418	ECCF1H221K	50V 220P	C821	ECKF1H223ZF	50V 0. 022U
C193	DD95390360	50V 39P	C423	EY10601620	16V 10U	C822, 823	ECKF1H223ZF	50V 0. 022U Δ
C194, 195	DK96222300	50V 2200P	C424	EY22600620	6. 3V 22U	C824, 825	DA17473110	50V 0. 047U Δ
C196	ECKF1E104ZV	25V 0. 1U	C425	ECKF1E104ZV	25V 0. 1U	C826, 827	ECKF1H223ZF	50V 0. 022U Δ
C201	DF15103350	50V 0. 01U	C426	EY22505040	35V 2. 2U	C841, 842	ECA1CPXS221B	16V 220U
C202	ECKF1E104ZV	25V 0. 1U	C427, 428	ECKF1E104ZV	25V 0. 1U	C851-853	ECKF1H103KB	50V 0. 01U Δ
C203	ECA1CPXS100B	16V 10U	C429	EY10601620	16V 10U	C861, 862	ECKF1H103KB	50V 0. 01U Δ
C204	ECKF1E104ZV	25V 0. 1U	C430	ECKF1E104ZV	25V 0. 1U	C871	DA17473110	50V 0. 047U Δ
C205, 206	ECA1CPXS100B	16V 10U	C431	EY10601620	16V 10U	C872	EA10601620	16V 10U
C207	ECKF1E104ZV	25V 0. 1U	C432	ECCF1H470JC	50V 47P	C873	DA17473110	50V 0. 047U
C208	ECA1CPXS100B	16V 10U	C433, 434	ECKF1E104ZV	25V 0. 1U	C874	EA10601620	16V 10U
C209	DF15103350	50V 0. 01U	C440	ECKF1E104ZV	25V 0. 1U	C875	DA17473110	50V 0. 047U Δ
C210	ECKF1E104ZV	25V 0. 1U	C441	DK98393200	16V 0. 039U	C876	EA10601620	16V 10U
C211	ECA1CPXS100B	16V 10U	C442	DK58474200	16V 0. 47U	C877	DA17473110	50V 0. 047U
C212-214	ECKF1E104ZV	25V 0. 1U	C443-446	ECKF1E104ZV	25V 0. 1U	C878	EA47601620	16V 47U
C215	ECA1EPXS101B	25V 100U	C447	EY10601620	16V 10U	CA01	ECA1CPXS100B	16V 10U
C216	ECKF1E104ZV	25V 0. 1U	C448	ECCF1H101JC	50V 100P	CA02	DA17473110	50V 0. 047U
C217	ECA1EPXS101B	25V 100U	C449	ECKF1E104ZV	25V 0. 1U	CA03	DF15104350	50V 0. 1U
C218-220	ECKF1E104ZV	25V 0. 1U	C450	EY10601620	16V 10U	CA04	DD38104010	25V 0. 1U



EXPLODED VIEWS

Cabinet parts

Loading Parts

A
B
C
D
E
F
G

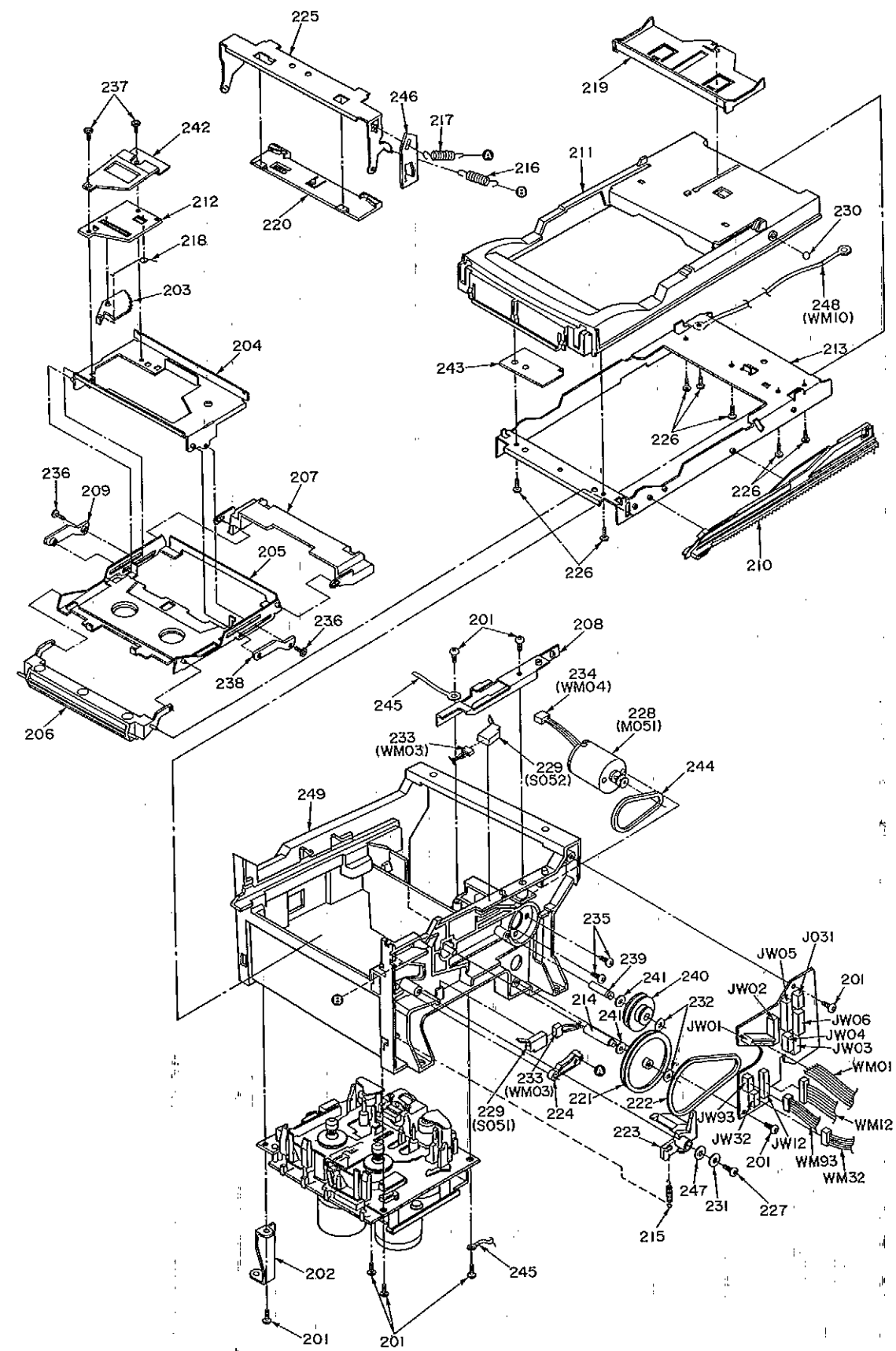
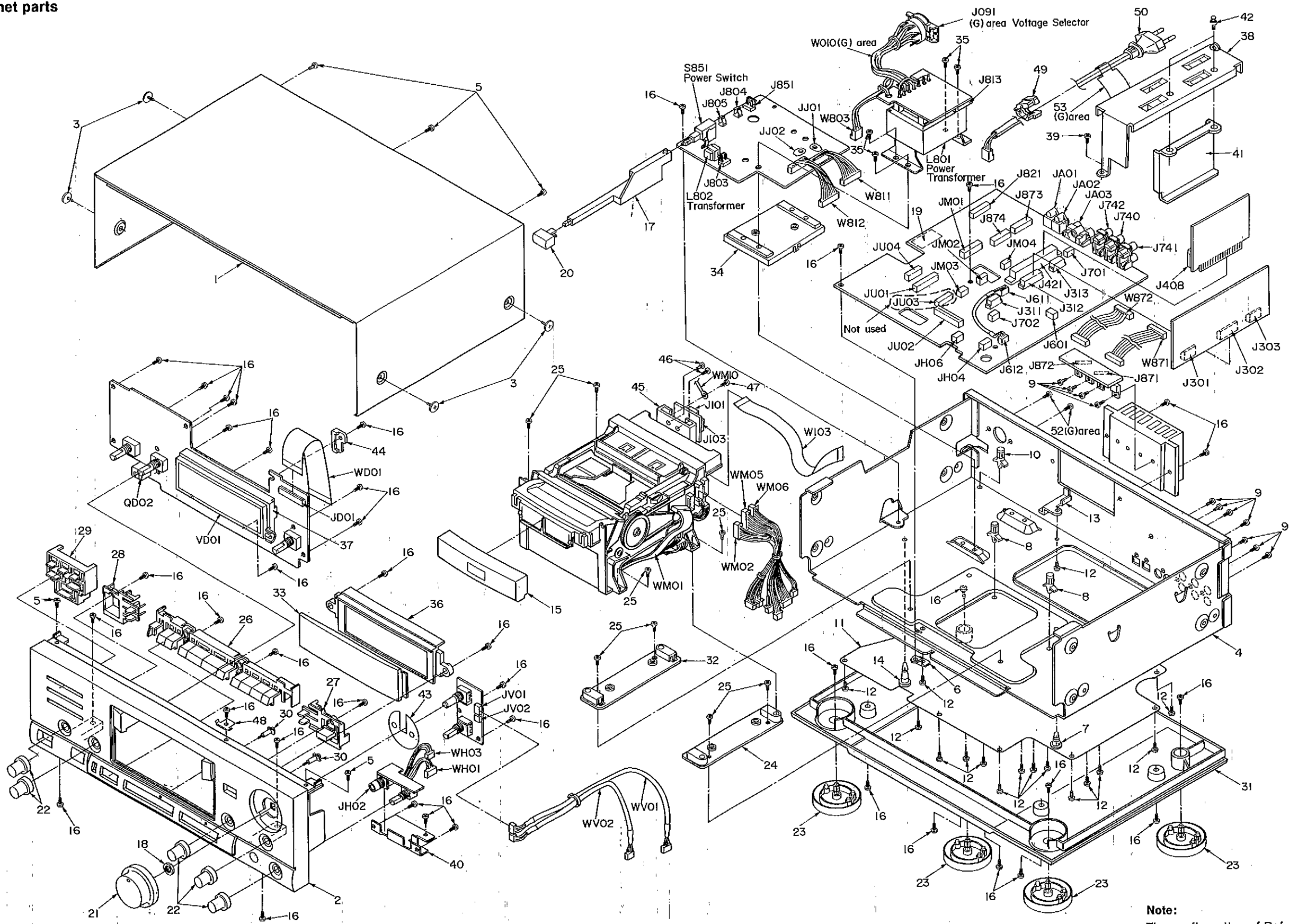

Note:
The configuration of Ref. No. 50 (AC power supply cord) differs according to area.

• Mechanical parts

(Top view)

(Bottom view)

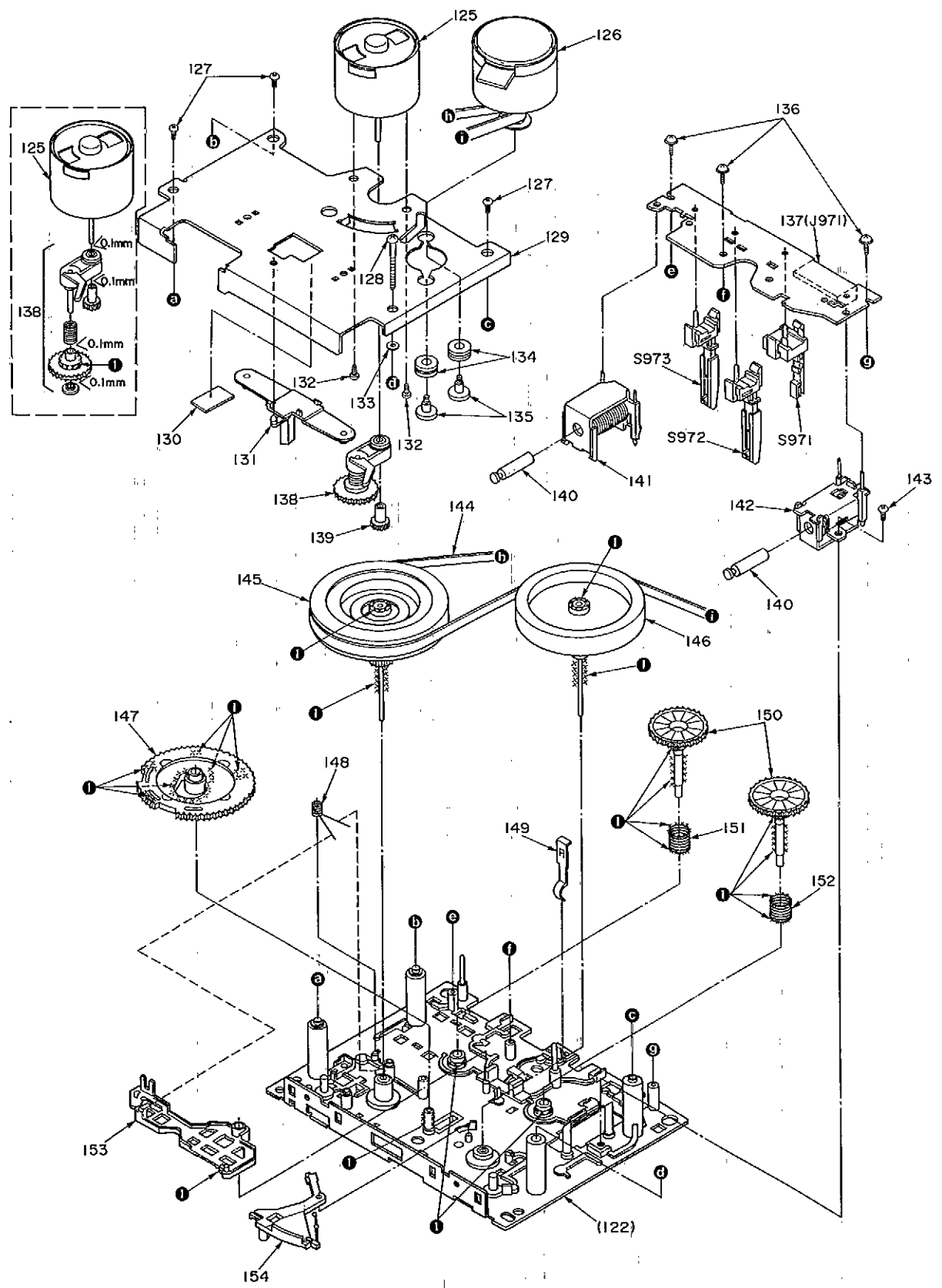
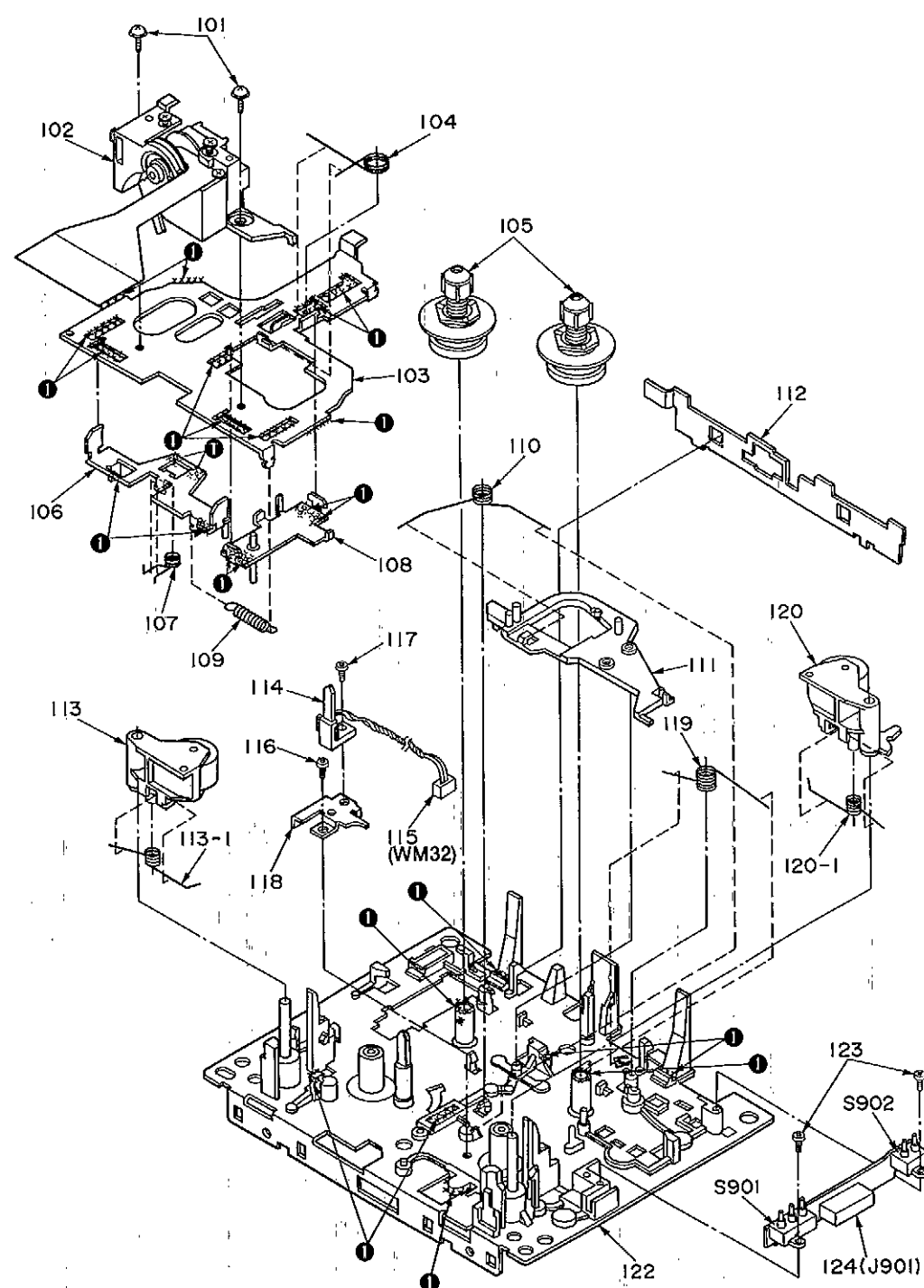

Note:
When changing mechanism parts,
apply the specified greases to areas
marked "x" as shown in the
drawing.

Ref. No.	Part Name	Part No.
●	FLOIL AK-152	SZZ0L18

REPLACEMENT PARTS LIST

Notes: *Important safety notice:
Components identified by Δ mark have special characteristics important for safety.
Furthermore, special parts which have purposes of fire-retardant (resistors), high-quality sound (capacitors), low-noise (resistors), etc. are used.
When replacing any of components, be sure to use only manufacturer's specified parts shown in the parts list.
*The parenthesized indications in the Remarks columns specify the areas. (Refer to the cover page for area.)
Parts without these indications can be used for all areas.
*Remote Control Ass'y:
Supply period for three years from termination of production.

Ref. No.	Part No.	Part Name & Description	Remarks	Ref. No.	Part No.	Part Name & Description	Remarks
		CABINET AND CHASSIS		41	009D109010	SHIELD PLATE	
				42	173H05010	CLAMPER	
				43	009D109390	SHIELD PLATE, REC VR	
1	RFKNSDC10PPK	TOP COVER ASS'Y		44	009D101010	HOLDER	
2	RFKNSDC10PPK	FRONT PANEL ASS'Y		45	009D160110	BRACKET, READ/WRITE P. C. B.	
3	011D010010	SCREW		46	XTB26*4J	SCREW	
4	RFKNSDC10G-K	CHASSIS ASS'Y	(G)	47	51100306S0	SCREW	
4	RFKNSDC10EGK	CHASSIS ASS'Y	(EG)	48	011D123030	CONTACTOR	
4	RFKNSDC10EBK	CHASSIS ASS'Y	(EB)	49	450H259010	BUSHING, AC P. SUPPLY CORD	
5	XTB3*10JFZ	SCREW		50	YC01800610	AC POWER SUPPLY CORD, W01	(EG, G) Δ
6	009D104130	RETAINER, MAIN P. C. B.		50	YC01800620	AC POWER SUPPLY CORD, W01	(EB) Δ
7	467H118010	SPACER, MAIN P. C. B.		52	51100306S9	SCREW	(G)
8	054J101040	P. C. B. SUPPORT		53	RQA0134	CAUTION LABEL (VOL. SELECTOR)	(G)
9	237K010010	SCREW				LOADING PARTS LIST	
10	054J101050	P. C. B. SUPPORT					
11	009D257120	BOTTOM LID		201	XTB3*8JFZ	SCREW	
12	XTB3*6JFZ	SCREW		202	009D109140	BRACKET	
13	011D104010	RETAINER, MAIN P. C. B.		203	009D002500	ARM KIT	
14	045H118010	SPACER, POWER P. C. B. SUPPORT		204	009D104500	RETAINER KIT	
15	RFKNSDC10CK	CASSETTE TRAY ASS'Y		205	009D163500	TRAY KIT	
16	XTB3*8JFZ	SCREW		206	009D002010	ARM	
17	011D121010	POWER SWITCH LINK		207	009D002020	ARM	
18	XNS7D	MUT		208	009D051010	GUIDE	
19	147T118010	SPACER		209	009D005020	CLAMPER	
20	RG00030	BUTTON, POWER		210	009D058010	GEAR	
21	011D154020	KNOB, REC LEVEL		211	009D064010	CASE	
22	009D154060	KNOB, TIM/NR/SEL/BAL/H. P		212	RFKNSDC10PPA	RETAINER ASS'Y	
23	RK40009-1	FOOT		213	009D105010	CHASSIS	
24	009D104120	RETAINER, MECHA BRACKET (R)		214	009D112010	SHAFT	
25	XTB3*20JFZ	SCREW		215	009D115010	SPRING	
26	011D270120	BUTTON, MECHA OPERATION		216	009D115020	SPRING	
27	009D270130	BUTTON, TEXT/COUNTER/TRAY		217	009D115030	SPRING	
28	009D270040	BUTTON, COUNTER/REPEAT		218	009D115040	SPRING	
29	009D270050	BUTTON, MARKER CONTROL		219	009D127010	CONTROL BOARD	
30	011D355020	PLAY/REC INDICET LENS		220	009D252010	PAD	
31	RFKNSDC10EGK	BOTTOM BOARD ASS'Y		221	009D262010	PULLEY	
32	009D104120	RETAINER, MECHA BRACKET (L)		222	009D264010	BELT	
33	011D158010	FL WINDOW		223	009D354010	LEVER	
34	009D104110	RETAINER, TRANS BRACKET		224	009D354020	LEVER	
35	51280315A0	SCREW		225	009D354030	LEVER	
36	011D160020	BRACKET, FL WINDOW		226	5130260500	SCREW	
37	009D271010	FL HOLDER		227	XTB3*10JFZ	SCREW	
38	009D104150	RETAINER, DCC P. C. B.		228	RFKNSDC10PPK	D. C. MOTOR ASS'Y (M051)	
39	51280310B0	SCREW		229	SS01020590	SLIDE SWITCH (S051, 052)	
40	011D160010	BRACKET, HEADPHONES					

Ref. No.	Part No.	Part Name & Description	Remarks	Ref. No.	Part No.	Part Name & Description	Remarks
230	61050010T0	BALL		129	RMA0048	FLYWHEEL PLATE	
231	54110149A0	WASHER		130	RMQ0325	SPACER	
232	009D114210	WASHER		131	RMD50142C	THRUST ANGLE	
233	YB00141200	CONNECTIVE CORD(4P), WM03		132	XSN26+3	SCREW	
234	YB00121590	CONNECTIVE CORD(3P), WM04		133	RHW31002	WASHER	
235	XSB3+4FZ	SCREW		134	RHG3032ZA	CUSHION	
236	XSN17+4BN	SCREW		135	RHD26002	SCREW	
237	51821702S0	SCREW		136	XTW2+8S	SCREW	
238	009D005010	CLAMPER		137	RJS9T7ZA	CONNECTOR(9P), J971	
239	009D112050	SHAFT		138	RXG0009	IDLER GEAR ASS'Y	
240	009D262020	PULLEY		139	RDG0034	REEL MOTOR GEAR	
241	59035402G9	WASHER		140	RUB428ZE	MOVING IRON CORE	
242	009D116020	SPACER		141	RSJ0003	SOLENOID	
243	009D116010	SPACER		142	RXQ0011	BRAKE SOLENOID	
244	009D264020	BELT		143	XTN26+4F	SCREW	
245	009D005030	HADE CORD		144	RDV0015	CAPSTAN BELT	
246	009D269010	ANGLE		145	RXF0007	FLYWHEEL (F)	
247	59069505G9	SPACER		146	1DW054YA	FLYWHEEL (R)	
248	YB00151850	CONNECTIVE CORD, WM10		147	RDG0221	MAIN GEAR	
249	RFKNSDC10PPB	FRAME ASS'Y		148	RUW147ZA	TRIGGER LEVER SPRING	
		MECHANISM		149	RUS6092C	SPRING	
101	XTW2+6L	SCREW		150	RXG0003	REEL TABLE GEAR	
102	RFKQSDC10-K	HEAD BLOCK (R/P) ASS'Y		151	RMB0298	BACK TENSION SPRING R	
103	RMK0152	HEAD BASE		152	RMB0299	BACK TENSION SPRING L	
104	RMB0229	SPRING, HEAD BASE		153	RML0037	TRIGGER LEVER	
105	RXR0013	REEL TABLE		154	RML0038	LEVER	
106	RFKRSDC10CK	ROD ASS'Y				PACKING MATERIAL	
107	RUW143ZA	SPRING		P1	011D801010	PACKING CASE	(G, EG)
108	RFKRSDC10BK	MAIN ROD		P1	011D801040	PACKING CASE	(EB)
109	RUD105ZA	SPRING		P2	011D809110	CUSHION (FRONT)	
110	RME0020	SPRING, BRAKE		P3	011D809120	CUSHION (BACK)	
111	RML0040-2	BRAKE LEVER		P4	157K811010	PROTECTION COVER(UNIT)	
112	RMA0550	PLATE		P5	XZB24X3C04	PROTECTION BAG (F. B., ACC.)	
113	RXP0005	PINCH ROLLER ARM				ACCESSORIES	
113-1	RUW141ZA	SPRING, PINCH ROLLER		A1	RFKSSDC10EGK	INSTRUCTION MANUAL ASS'Y	(EG)
114	SPI-306-03	END SENSOR		A1	RFKSSDC10G-K	INSTRUCTION MANUAL ASS'Y	(G)
115	REX0419Y	READ WIRE BLOCK(3P), WM32		A1	011D851040	INSTRUCTION MANUAL	(EB)
116	XQN2+CM25	SCREW		A2	SFDHM03N02	STEREO CONNECTION CABLE	
117	XSN2+4	SCREW		A3	ZK011D0020	REMOTE CONTROL TRANSMITTER	
118	RMA0551	SENSOR ANGLE		A4	YJ04001280	POWER PLUG ADAPTOR	(G)△
119	RUW142ZA	SPRING		A5	RQA0013	WARRANTY CARD	(EB, EG)
120	RXP0004	PINCH ROLLER ARM (F)					
120-1	RUW140ZC	SPRING, PINCH ROLLER ARM (F)					
122	RFKRSDC10AK	CHASSIS ASS'Y					
123	XTB2+6J	SCREW					
124	SJTD613	CONNECTOR(6P), J901					
125	NMN-6F4RA88	REEL MOTOR					
126	RFM133ZA	DC MOTOR					
127	XTN26+7J	SCREW					
128	XTN26+26F	SCREW					

1467